

The background features several large, overlapping, wavy lines composed of many thin, parallel lines, creating a sense of motion and depth. These lines are light gray and curve across the page, framing the central text.

# Mounting

AM 150 | AM 300 | AM 500 | AM 800

AIRMASTER

## SAFETY INSTRUCTIONS



This Manual must be read before installing the Airmaster air handling unit. Following this Manual will ensure this product is operated correctly.

The manufacturer cannot be held liable for damage arising from use or installing in contravention of these instructions.

The installation engineer is responsible for ensuring that the unit is installed according to current regulations and standards.

The manufacturer reserves the right to make changes without notice. All values stated are nominal values and can be affected by local conditions.

When installing the air handling unit in a room with a fire or stove drawing air from the room, all applicable provisions must be observed.

Failure to observe the warnings indicated by a danger symbol implies a risk of personal injury or damage to property.

The unit should not be installed in rooms with abrasive particles or flammable or corrosive gas in the air, in wet rooms or explosion-protected rooms.

This manual relates to the Airmaster unit it accompanies plus all equipment, and must be given to and saved by the unit's owner.

The unit should not be used without the filters specified in the Operator's Manual.

All necessary data and guides to network integration can be downloaded from [www.airmaster-as.com](http://www.airmaster-as.com).

## WARNINGS



Service covers may not be opened without first disconnecting the unit's power supply and preventing use.



The unit may not be started up until all service covers and grates on duct connections have been installed.



The installer must wear personal protective safety equipment, such as safety shoes, during the installation of the unit

Place of installation and serial numbers (S/N):

Type: \_\_\_\_\_

Delivery date: \_\_\_\_\_

Place of installation: \_\_\_\_\_

S/N of Air handling unit: \_\_\_\_\_

S/N of Cooling Module: \_\_\_\_\_

## Table of Contents

<b>1. General Information.....</b>	<b>5</b>
<b>2. Technical Specifications .....</b>	<b>6</b>
<b>3. Installation .....</b>	<b>6</b>
3.1. Positioning of the Air Handling Unit.....	6
3.2. Ceiling Brackets.....	7
3.3. Installation of Wall Frames and the Drilling of Duct Holes.....	8
3.4. Installation of the Cooling Module CC 500 or 800.....	10
3.5. Installation of the Air Handling Unit AM 500 and 800 to the wall frame or cooling module.....	11
3.5.1. Installation with Ceiling Frame .....	12
3.6. Installation of the Air Handling Unit AM 150, AM 150 with CC 150 (Cooling Module) and AM 300 .....	13
3.6.1. Assembling the AM 150 and CC 150 before installation .....	13
3.6.2. Installation of the Air Handling Unit.....	13
3.6.3. Installation with Ceiling Frame .....	14
3.6.4. Installation of the Service Cover .....	14
3.7. Ducts and Grilles.....	15
3.8. Roof Cap.....	15
3.9. Sealing the Gaps Around Ducts .....	15
3.10. Jointing against the ceiling .....	16
3.11. Fitting of Panels.....	16
3.12. Installation Check .....	16

<b>Appendix 1 Dimensional Drawings .....</b>	<b>17</b>
AM 150, AM 150 - CC (with Cooling Module) and AM 300 .....	17
AM 500 and 800 H .....	18
AM 500 and 800 V .....	19
AM 500 and 800 DIDE .....	20
AM 500 and 800 H - CF (Ceiling Frame) .....	21
AM 500 and 800 V - CF (Ceiling Frame) .....	22
AM 500 and 800 H - CC (with Cooling Module) .....	23
AM 500 and 800 HDIDE - CC (with Cooling Module) .....	24
Isometric View .....	25
Model Versions AM 500 and 800 .....	29
<b>Appendix 2 Additional Dimensions .....</b>	<b>30</b>
Connections AM 500 .....	30
Connections AM 500 - CC .....	31
Connections AM 800 .....	31
Connections AM 800 DIDE .....	32
Connections AM 800 - CC .....	32
Connections AM 800 DIDE - CC .....	33
Ceiling Bracket, Angle .....	33
Ceiling Bracket, Adjustable .....	33
Positioning of the Ceiling Brackets .....	34
AM 500 and 800 .....	34
AM 500 and 800 with Cooling Module (CC) .....	34
Positioning of the Ceiling Frame .....	35
AM 500 and 800 .....	35

# 1. General Information

## Scope of Delivery:

The Airmaster air handling unit is packed on a pallet in one or more cardboard boxes. All individual parts can be found in the box(es), depending on the customer's order.

Please check the delivery before installation. The most important parts are shown below. The scope of delivery can be seen from the delivery note.

- 1. Airmaster air handling unit (AM)



- 2. Wall frame (fitted for 1. or 3.)

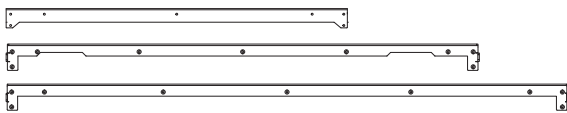

- 3. Cooling module (CC - optional)

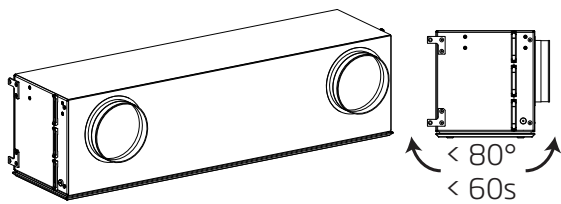
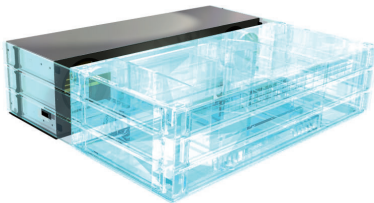

*Cooling modules must be stored and transported on the case cover. The unit may, however, be tipped up to 80 degrees for up to 60 seconds.*

- 4. Panel set (a set consists of one to three long panels and double that number of short panels)

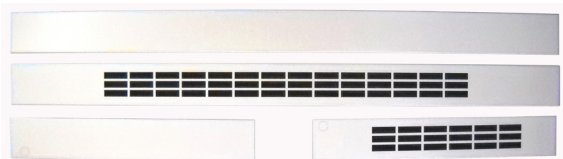

- 5. Ceiling fittings (optional)

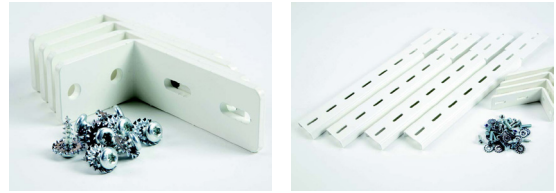

- 6. Control panel

Airlinq Viva



or

Airlinq Orbit



- 7. Set of pipes (optional)



- 8. Grilles (optional)

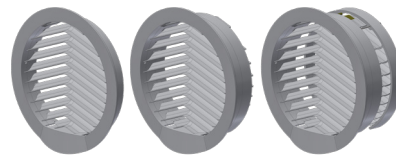

- 9. Operator's Manual (for programming) and Mounting Instructions and Installation Manual (for installation); to be handed over to the owner!



## 2. Technical Specifications

		AM 150	AM 300	AM 500	AM 800
Weight, Standard unit	kg	53	85	108	156,5
Weight, Standard unit + Cooling module	kg	82	-	190,8	257,2
Colour, Panel	RAL	-	-	9010	9010
Colour, Case	RAL	9010	9010	7024	7024
Dimensions	mm	See "Dimensional Drawings"			

## 3. Installation



The installation engineer is responsible for ensuring that the Airmaster air handling unit is properly secured in a horizontal position.



The installation engineer is responsible for ensuring that any existing functions in the wall/ceiling (e.g. vapour barrier) are restored and fully functional once the unit has been installed.

Read this section "Installation" fully before starting installation!

### 3.1. Positioning of the Air Handling Unit

The diagram below shows the most important dimensions relating to the positioning of the unit.

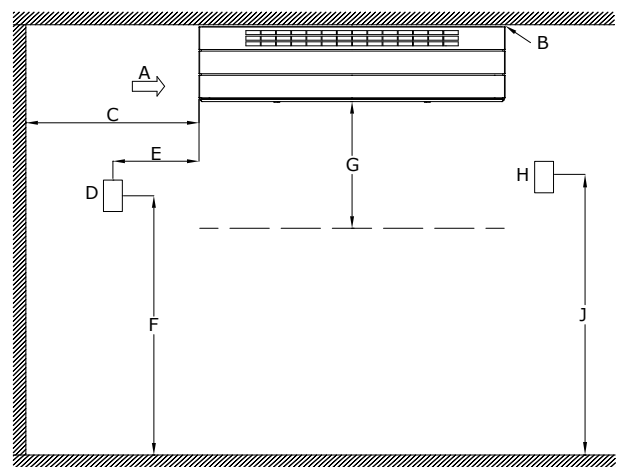

A: Extraction (may also be on the right side of the unit)

B: Distance from ceiling: Max. 50 mm

C: Min. distance from wall: 0.5 m

D: External CO<sub>2</sub> sensor

E: Approximately 1 m

F: Approximately 2 m

G: Free space for maintenance work min. 0.95 m

H: External PIR sensor

J: Approximately 2,25 m (1,8-2,5 m)

**A CO<sub>2</sub> sensor must not be fitted close to a window or door.**

**A smoke detector must not be too close to the inlet air flow and extract air flow.**

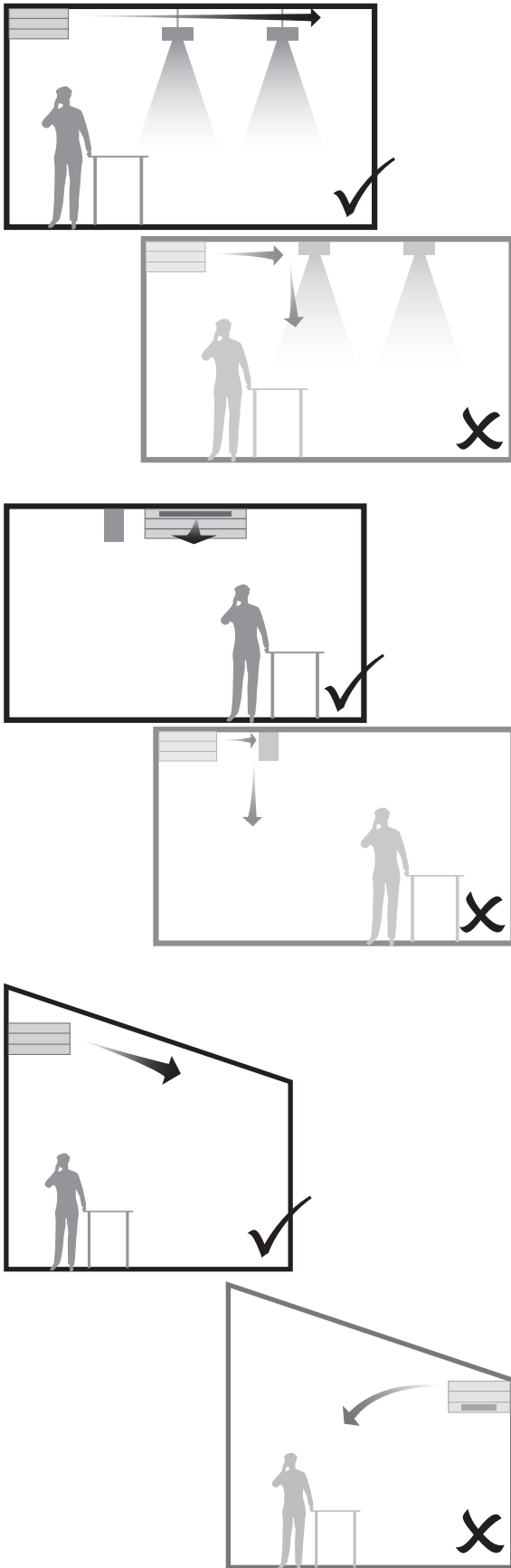

### 3.2. Ceiling Brackets

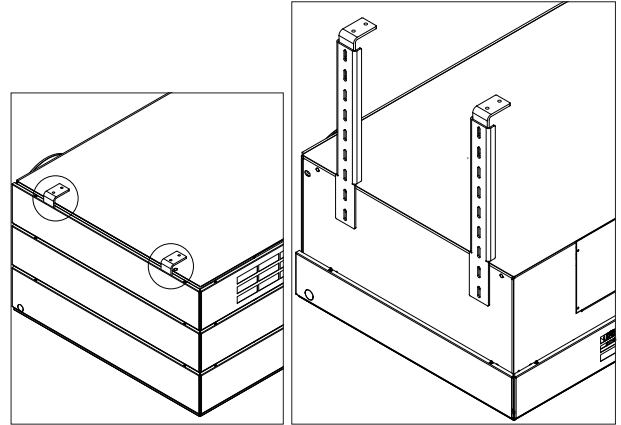

The purpose of the ceiling brackets is to hold a wall-mounted unit in place when the attachment to the wall frame alone does not provide sufficient support. This is the case, for example, when the unit is equipped with a cooling module, when the wall is not sufficiently sound or when the unit is to be fitted in a free-suspended position. Not at the AM 150 and AM 300.

The holes for securing the ceiling brackets are at the top of the unit and the cooling module on both sides. In this connection, see "Appendix 1 Dimensional drawings" or "Appendix 2 Additional Dimensions".

*If ceiling brackets are used, the distance from the wall frame/unit to the ceiling must be adjusted as the ceiling brackets protrude over the top edge of the unit by up to 30 mm!*

### 3.3. Installation of Wall Frames and the Drilling of Duct Holes



**NB!** The air handling unit must be mounted on a solid supporting base by using all possible attachment points. If the wall itself is not sufficiently solid, the air handling unit can be additionally fastened to the ceiling pursuant to 'Appendix 1 Dimensional Drawings' and 'Appendix 2 Additional Dimensions'.



**NB!** If the air handling unit is not properly affixed, there is a high risk of the air handling unit disengaging from its attachment fittings and falling down. This constitutes a risk of damaging materials and/or causing serious personal injury.



**NB!** The attachment material will depend on the supporting base and the air handling unit and must be suitable for properly supporting the unit's weight of up to 257 kg on the supporting base.

The wall to which the unit is fitted must have an even surface. If the surface is too uneven, fitting of the frame may be out of true. This may lead to leaks and an increased noise level during operation of the unit.

It is recommended that the duct holes be drilled 10-15 mm larger than indicated on the drawings as this will allow for subsequent insulation, will prevent direct contact with the wall, and will allow for a vapour barrier etc. to be restored. A rubber diaphragm for restoration of the function of the vapour barrier is optional available and can be delivered by Airmaster.

Duct holes in the wall must have an outward downward gradient of 1-2% to prevent heavy rain from entering the unit.

The holes for the roof ducts must be made oval to be able to install the unit. 'Appendix 1 Dimensional drawings'.

1. Hold the wall frame against the wall under the ceiling.

AM/AM+CC	150, 300	500, 800
Distance (A) wall frame to ceiling [mm]	0	0
Optical air gap between unit and ceiling [mm]	14	7,5

If the air gap (L) needs to be increased, e.g. if the unit is to be installed with ceiling fittings (see also sections "Ceiling Brackets" and "Appendix 2 Additional Dimensions"), distance (A) should be increased.

2. Mark all holes and the top edge and left edge of the wall frame on the wall. Trial fit the wall frame if necessary.

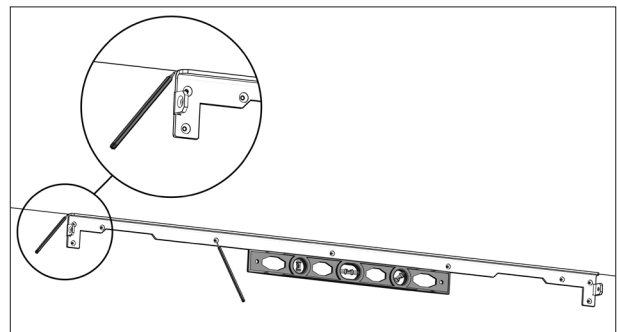



3. Mark the holes for the ducts according to "Appendix 1 Dimensional Drawings".

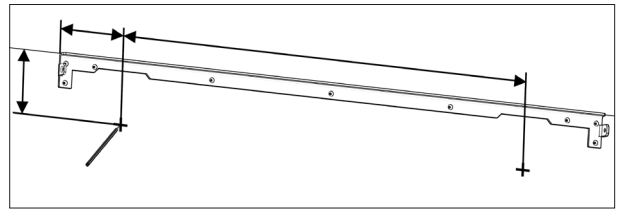

4. Drill all marked holes.

**AM 150 and AM 300: See below.**

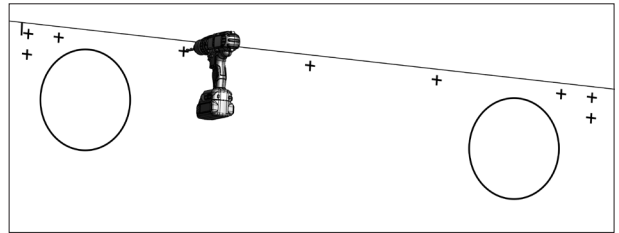

5. Fit the wall frame.

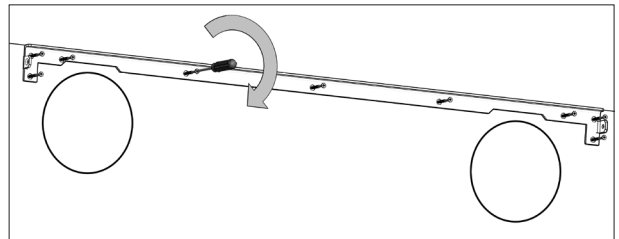

**Only AM 150 and AM 300:**

4. Drill the holes for the ducts and the frame (1, 2 or 1+2) in accordance with "Dimensional Drawings".

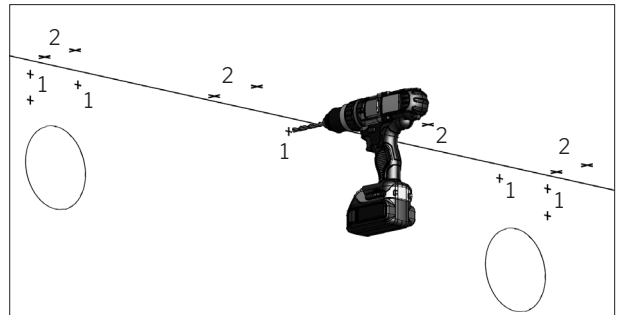

5. Fit the frame in a horizontal position. (1, 2 or 1+2).

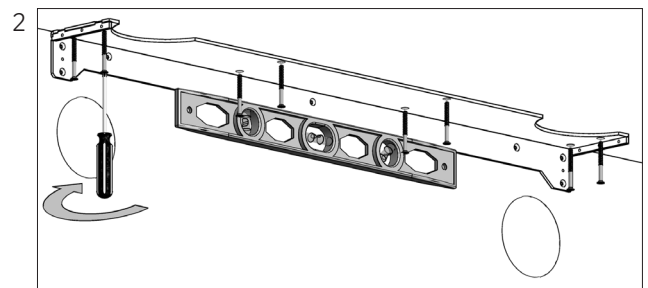
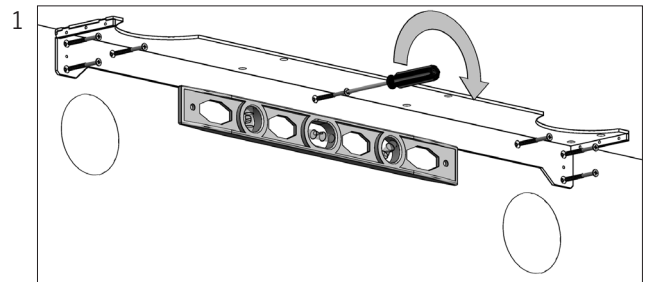

### 3.4. Installation of the Cooling Module CC 500 or 800

*The cooling module has to be adjust into a horizontal position.*

1. Drill, if relevant, any holes for the ceiling brackets according to the dimension drawings in “Appendix 2 Additional Dimensions” and attach the ceiling brackets

2. Appropriate lifting equipment is used to lift the cooling module into place on the wall frame.

*We would point out that, when lifting the cooling module a protective underlay must be placed beneath the service cover to prevent scratches to the service cover. This underlay may for example be strong, clean cardboard or equivalent.*

3. Press the cooling module against the wall frame and use the accompanying bolts to screw it tightly to the frame and, if relevant, to the ceiling brackets.

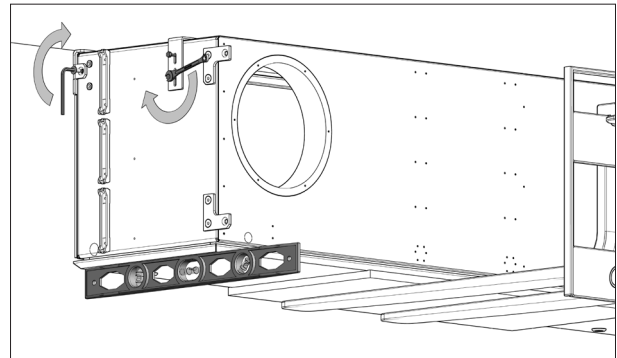
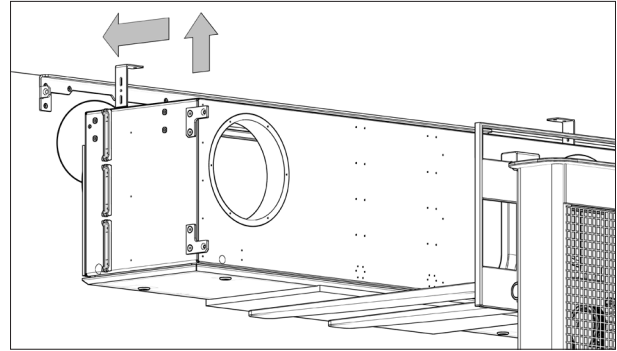
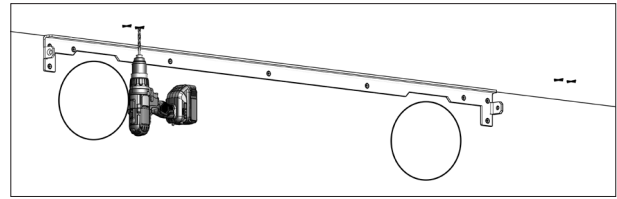

### 3.5. Installation of the Air Handling Unit AM500 and 800 to the wall frame or cooling module

*The unit has to be adjust into a horizontal position.*

1. Possibly drill the holes for the ceiling brackets in accordance with the dimensional drawings in "Appendix 2 Additional Dimensions" and attach the ceiling brackets.
2. Lift the air handling unit up to the cooling module/wall frame, using appropriate lifting equipment.

*When lifting the unit a protective underlay must be placed beneath the service cover to prevent scratches to the service cover. This underlay may for example be strong, clean cardboard or equivalent.*

3. Push the Airmaster air handling unit against the cooling module/wall frame and screw securely to the frame using the bolts provided.
4. Attach the unit to the ceiling brackets.

5. Draw the leads of the cooling module over to the air handling unit.
6. Note the type, date supplied, place of installation and serial numbers (S/N) of the air handling unit and the cooling module on page 2 of both the Installation Manuals and the Operator's Manual.

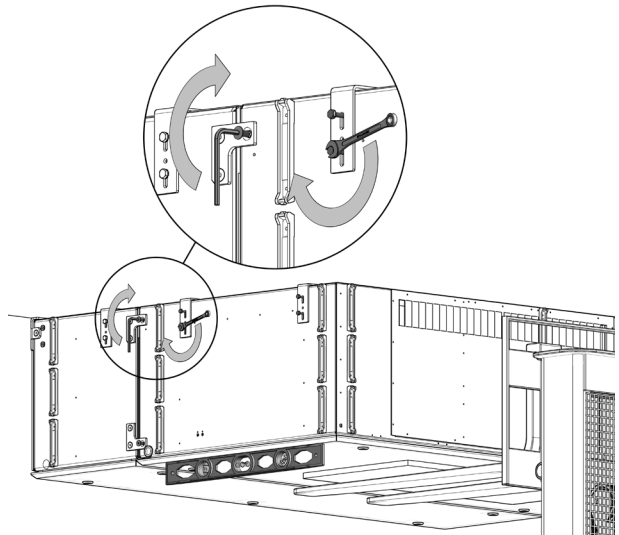
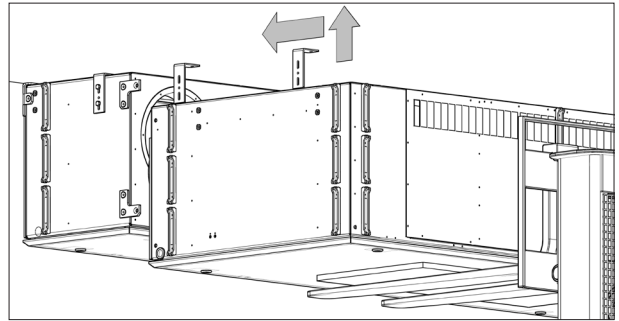
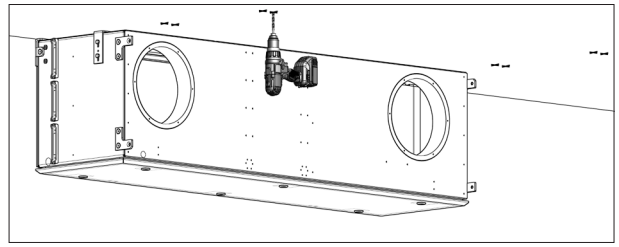

### 3.5.1. Installation with Ceiling Frame

*The unit has to be adjust into a horizontal position.*

1. Drill the holes for the ducts and the frame in accordance with “Appendix 1 Dimensional Drawings” and “Appendix 2 Additional Dimensions”. (See also section “Wall Frame and Duct Holes”)

*The attachment point for the air handling unit on the ceiling frame for AM 500 and 800 is adjustable. It is possible to adjust the vertical position of the air handling unit and the duct holes up to 20 mm.*

2. Lift the air handling unit up to the ceiling, using appropriate lifting equipment.

*We would point out that, when lifting the unit a protective underlay must be placed beneath the service cover to prevent scratches to the service cover. This underlay may for example be strong, clean cardboard or equivalent.*

3. Lift the air handling unit to its final position and mount the ceiling frame securely to the ceiling.

4. Adjust the air handling unit into a horizontal position and secure it to the ceiling frame.
5. Note the type, date supplied, place of installation and serial numbers (S/N) of the air handling unit on page 2 of both the Installation Manuals and the Operator’s Manual.

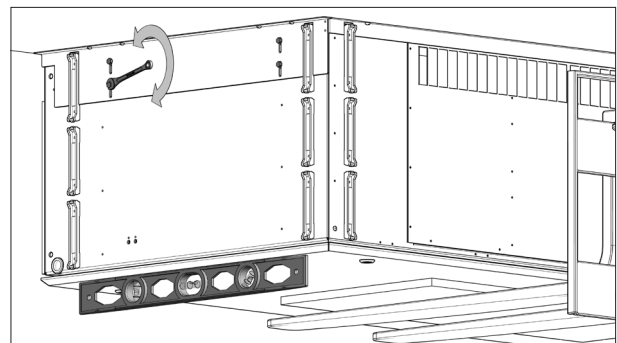
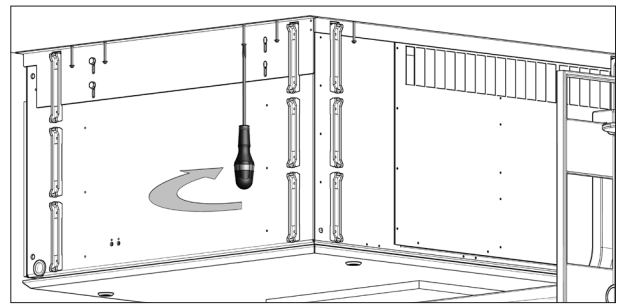
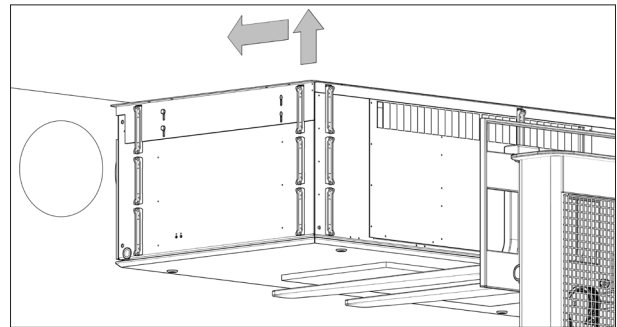
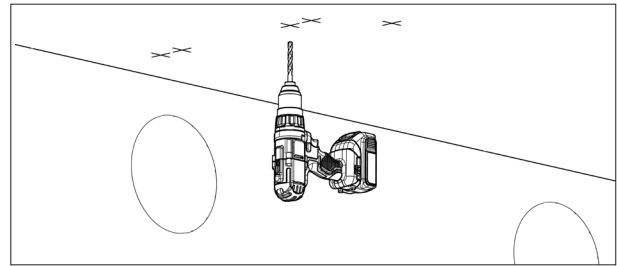

### 3.6. Installation of the Air Handling Unit AM 150, AM 150 with CC 150 (Cooling Module) and AM 300

#### 3.6.1. Assembling the AM 150 and CC 150 before installation

1. Dismantle any duct connectors from the rear side of the air handling unit.
2. Place the cooling module behind the air handling unit on a firm, even surface.

*Place a protective underlay beneath the units to prevent scratches to the units. This underlay may for example be strong, clean cardboard or equivalent.*

3. Press the air handling unit and cooling module completely together.
4. Screw the cooling module's mounting fittings onto the air handling unit. The enclosed screws are mounted on the air handling unit.

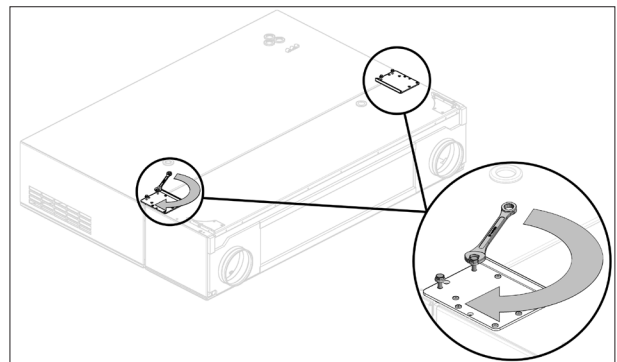
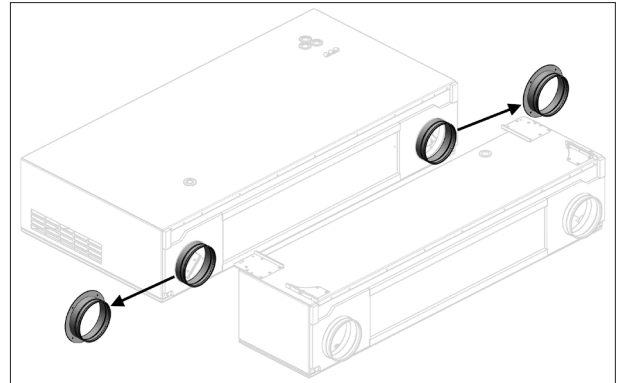

#### 3.6.2. Installation of the Air Handling Unit

*The unit has to be adjust into a horizontal position.*

1. Lift the air handling unit up to the frame, using appropriate lifting equipment.

*When lifting the unit a protective underlay must be placed beneath the unit to prevent scratches to the unit. This underlay may for example be strong, clean cardboard or equivalent.*

2. Draw the leads and the condensate hose of the unit from the connection points past the frame.
3. Push the unit onto the frame.

*Lead the mounting brackets on the unit within the frame.*

4. Press the unit all the way against the wall; insert a suitably pointed object, such as an awl, through the frame's centring holes and cooling module bracket so they line up with one another. Then mount the cooling module by screwing it onto the frame.
5. Repeat on the other side.
6. Adjust the air handling unit into a horizontal position with the adjusting screws. For AM 150 with CC 150, it may be necessary to adjust between the units.

**Max pressure per adjusting screw:**

**AM 150: 330 N**

**AM 150 + CC 150: 737 N**

**AM 300: 450 N**

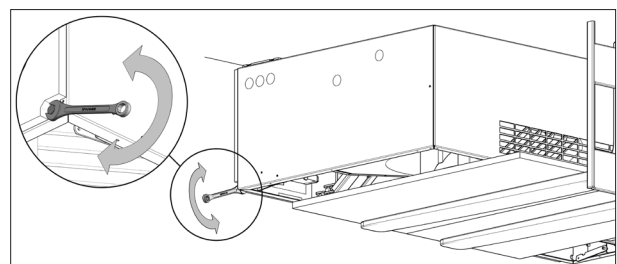
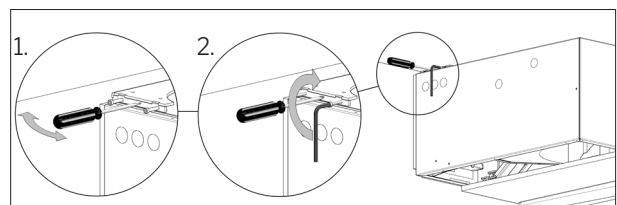
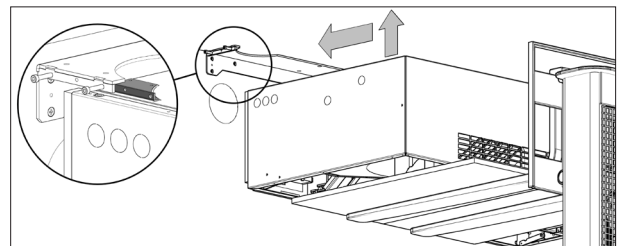

### 3.6.3. Installation with Ceiling Frame

*The unit has to be adjust into a horizontal position.*

1. Lift the air handling unit up to the ceiling, using appropriate lifting equipment.

*When lifting the unit a protective underlay must be placed beneath the unit to prevent scratches to the unit. This underlay may for example be strong, clean cardboard or equivalent.*

2. Draw the leads and the condensate hose of the unit from the connection points past the ceiling frame.
3. Lift the air handling unit to its final position.
4. Push the unit into the wall and mount the ceiling frame securely to the ceiling.

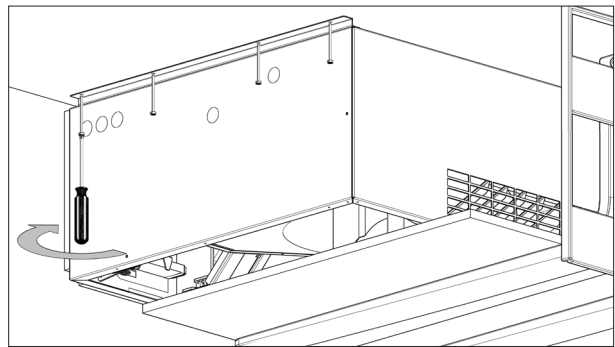
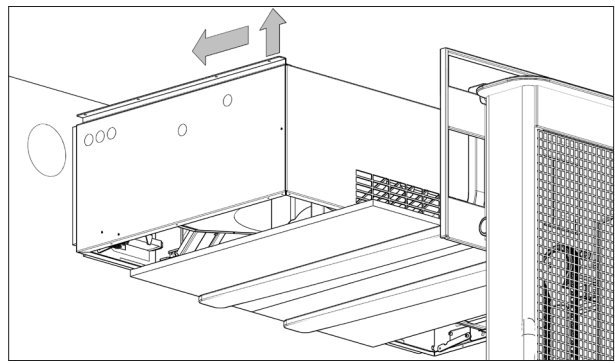

### 3.6.4. Installation of the Service Cover

1. Lift the service cover up to the air handling unit, using appropriate lifting equipment.

*We would point out that, when lifting the service cover a protective underlay must be placed beneath the service cover to prevent scratches to the service cover. This underlay may for example be strong, clean cardboard or equivalent.*

2. The short hinges mounted on the service cover are put over the bolts on the cabinet and secured using the two lock nuts provided, without tightening the hinges completely.

*At the AM 150 the supply air filter must be removed.*

3. The long hinges mounted on the cabinet are mounted using the two screws that are provided on the service cover.

*At AM 150 the supply air filter must be mounted again.*

4. The earth wire has to be connected on the hinge side from the cabinet to the service cover.
5. Carefully close the service cover while it is supported.

*The service cover is heavy. First close the locks on the inlet side and then the locks on the frame side.*

6. Note the type, date supplied, place of installation and serial numbers (S/N) of the air handling unit on page 2 of both the Installation Manuals and the Operator's Manual.

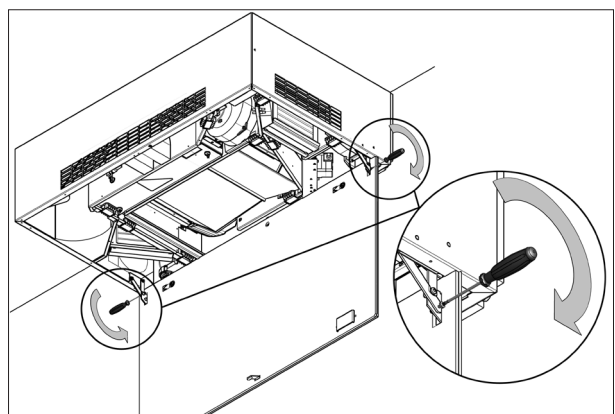
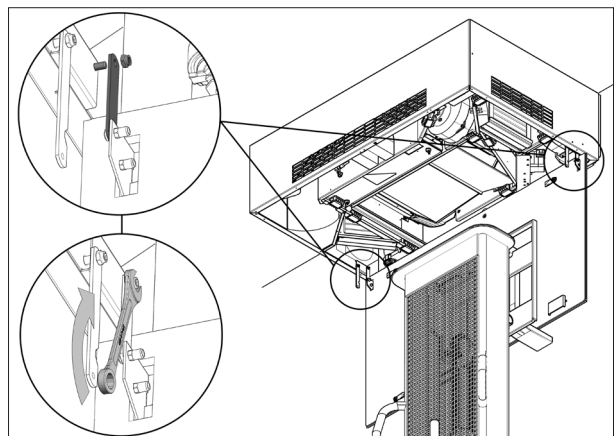

### 3.7. Ducts and Grilles

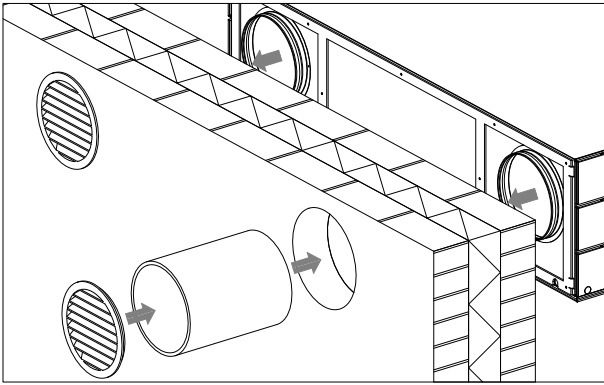

The materials needed and method of fitting the ducting depend on the unit, the options chosen and the customer's order. For this reason, we can provide only general instructions for fitting the ducts.

The length of the ducting is calculated on the basis of the thickness of the wall/dimensions of the roof.

*Please note that the duct holes in the wall must have an outward downward gradient of 1-2% to prevent heavy rain from entering the unit.*

*Exhaust air ducts and supply air ducts must be insulated against condensation on the ducts, if they are within the building envelope. The extract air ducts and inlet air ducts must be insulated against temperature loss and condensation forming inside the ducts if they are mounted outside the building envelope, or run through an unheated room.*

*Condensation and heat insulation should be performed according to standards and rules in effect.*

*Fire requirements according to standards and rules in effect must be observed.*

*The installation of ventilation ducts should be performed according to standards and rules in effect.*

*Exhaust air ducts and supply air ducts must be insulated against noise if they are visible.*

Finally, fit a suitable circular grille with the slats pointing downwards on the outside of the outer wall or a roof cap up on the roof.

To avoid an increase in noise level, it is important that the ducts should not get twisted or compressed against the exhaust air spigot and supply air spigot of the unit.

**Remember to seal around the penetrations. See section 'Sealing the Gaps Around Ducts'.**

### 3.8. Roof Cap

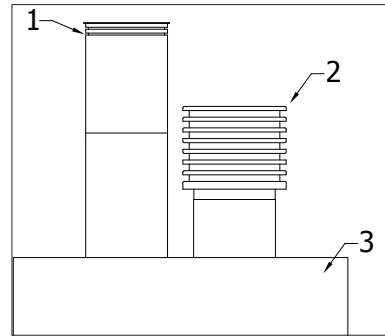

Fit roof caps on the roof to finish off the installation of exhaust and supply through a roof. Installation will depend on the roof construction (3). The illustration shows which roof caps are for exhaust (1) and intake (2).

**Fire requirements for the installation of multiple systems must be observed according to the standards and rules in effect.**

### 3.9. Sealing the Gaps Around Ducts

Sealing of the gaps around ducts is performed as shown in the sectional drawing below.

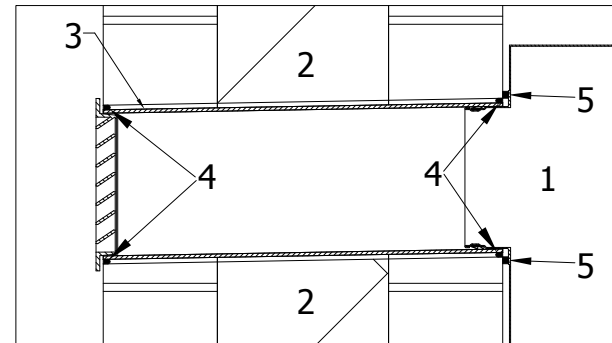

Application of a seal (shown here on a model with wall ducts) is important at the ducts (3) inside and the outside edges (4) in order to prevent draughts between the unit (1) and the wall/roof (2) as well as between the ducts (3) and the wall/roof (2).

Sealing on the inside between the pipes (3) and the wall/ceiling (2) can also be performed between the air handling unit (1) and the wall/roof (2) at position (5) before fitting the air handling unit.

Depending on the condition of the wall/ceiling and the dimensions of the air handling unit, a sealant that retains elasticity over the long term or expanding sealing tape can be used to obtain a flexible seal. This material is to be applied to the rear of the unit around the air connection fittings, or at the side of the duct holes on the wall to even out irregularities on the wall/ceiling.



### 3.10. Jointing against the ceiling

Airmaster recommends jointing the gap between the unit's top plate and the ceiling if the unit is mounted in a fully visible manner. The jointing on the sides and in the front can be carried out with, for example, joint backing strip or joint strip with a suitable thickness. Jointing the back edge is not necessary.

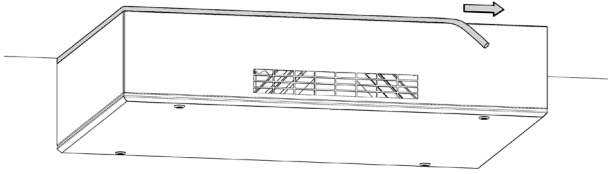

### 3.11. Fitting of Panels

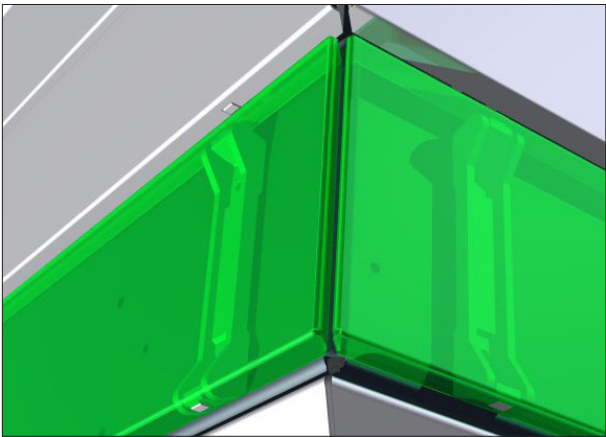
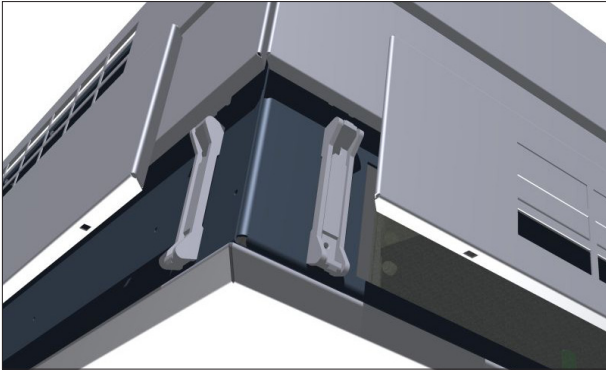

The panels must only be fitted once the unit, complete with all equipment, has been fitted and connected, and the functions of the unit thoroughly tested. Not at the AM 150 and AM 300.

Press the panels to the clips on the unit until they attach securely to the clips.

### 3.12. Installation Check

yes no

Serial numbers noted	<input type="checkbox"/>	<input type="checkbox"/>
Wall frame fitted	<input type="checkbox"/>	<input type="checkbox"/>
Cooling module fitted	<input type="checkbox"/>	<input type="checkbox"/>
Safety tape removed	<input type="checkbox"/>	<input type="checkbox"/>
Unit fitted	<input type="checkbox"/>	<input type="checkbox"/>
Ceiling fittings attached	<input type="checkbox"/>	<input type="checkbox"/>
Ducts and grilles fitted	<input type="checkbox"/>	<input type="checkbox"/>
Roof cap fitted	<input type="checkbox"/>	<input type="checkbox"/>
Screws retightened	<input type="checkbox"/>	<input type="checkbox"/>

Name of installation engineer:

Comment:



## **Appendix 1 Dimensional Drawings**

**AM 150, AM 150 - CC (with Cooling Module) and AM 300**

See the attached dimensional drawing.

# AM 500 and 800 H

Shown here: AM 500 HB with Extract on the right side and one panel row.

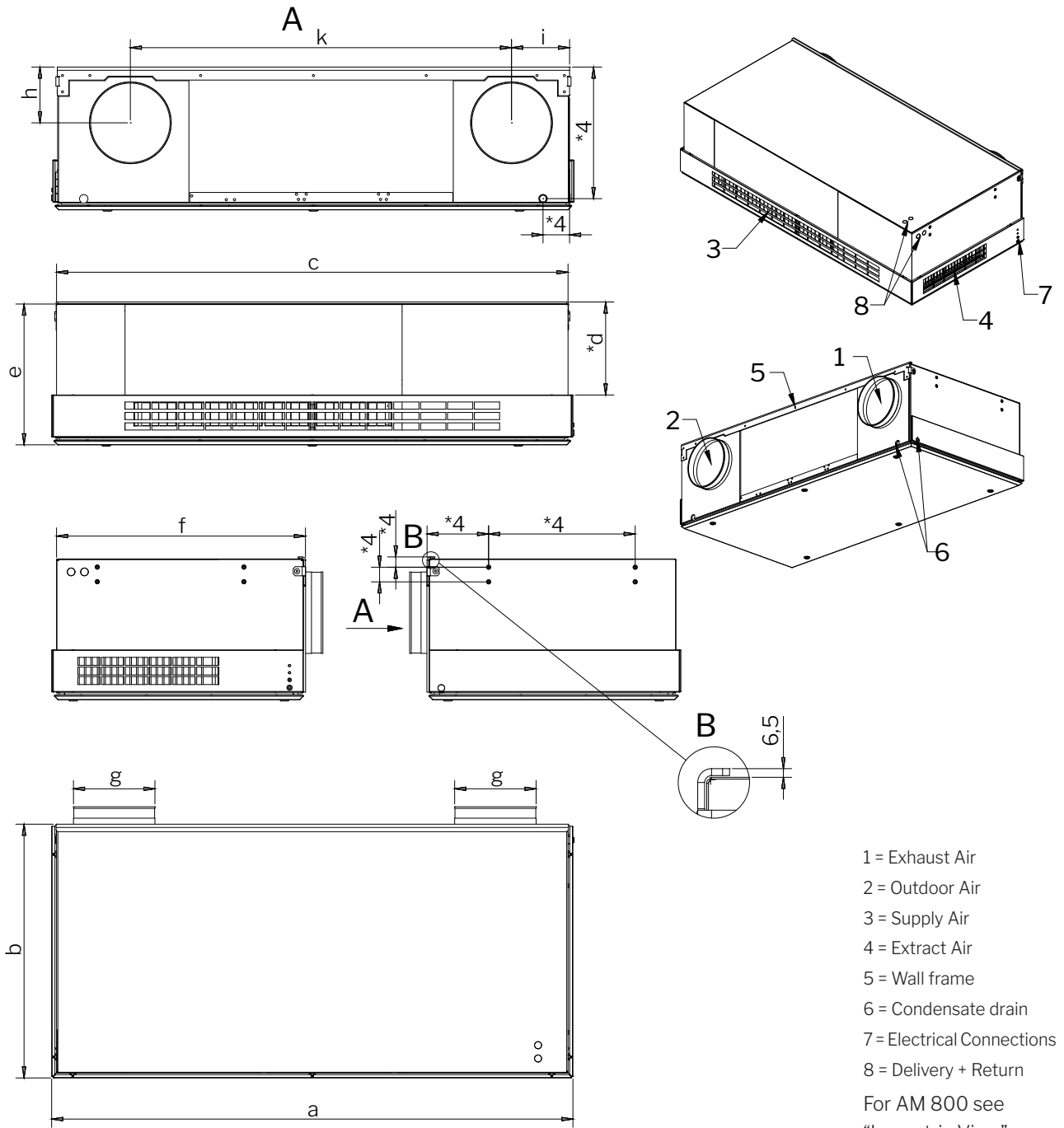

- 1 = Exhaust Air
  - 2 = Outdoor Air
  - 3 = Supply Air
  - 4 = Extract Air
  - 5 = Wall frame
  - 6 = Condensate drain
  - 7 = Electrical Connections
  - 8 = Delivery + Return
- For AM 800 see "Isometric View".

AM	a	b	c	d	e	f	g	h*1	i*2	k
500	1600	779	1570	286	432	764	250	171	178	1170
800	1910	915	1880	310	467	901	315	252	242	1433

\*1 Distance from top edge of wall frame to centre hole.  
 \*2 Distance from left edge of wall frame (without mounting pin) to centre hole.  
 \*4 See "Appendix 2 Additional Dimensions".  
 \*d Measure, including wall frame.

# AM 500 and 800 V

Shown here: AM 500 VC with Extract on the right side and two panel rows.

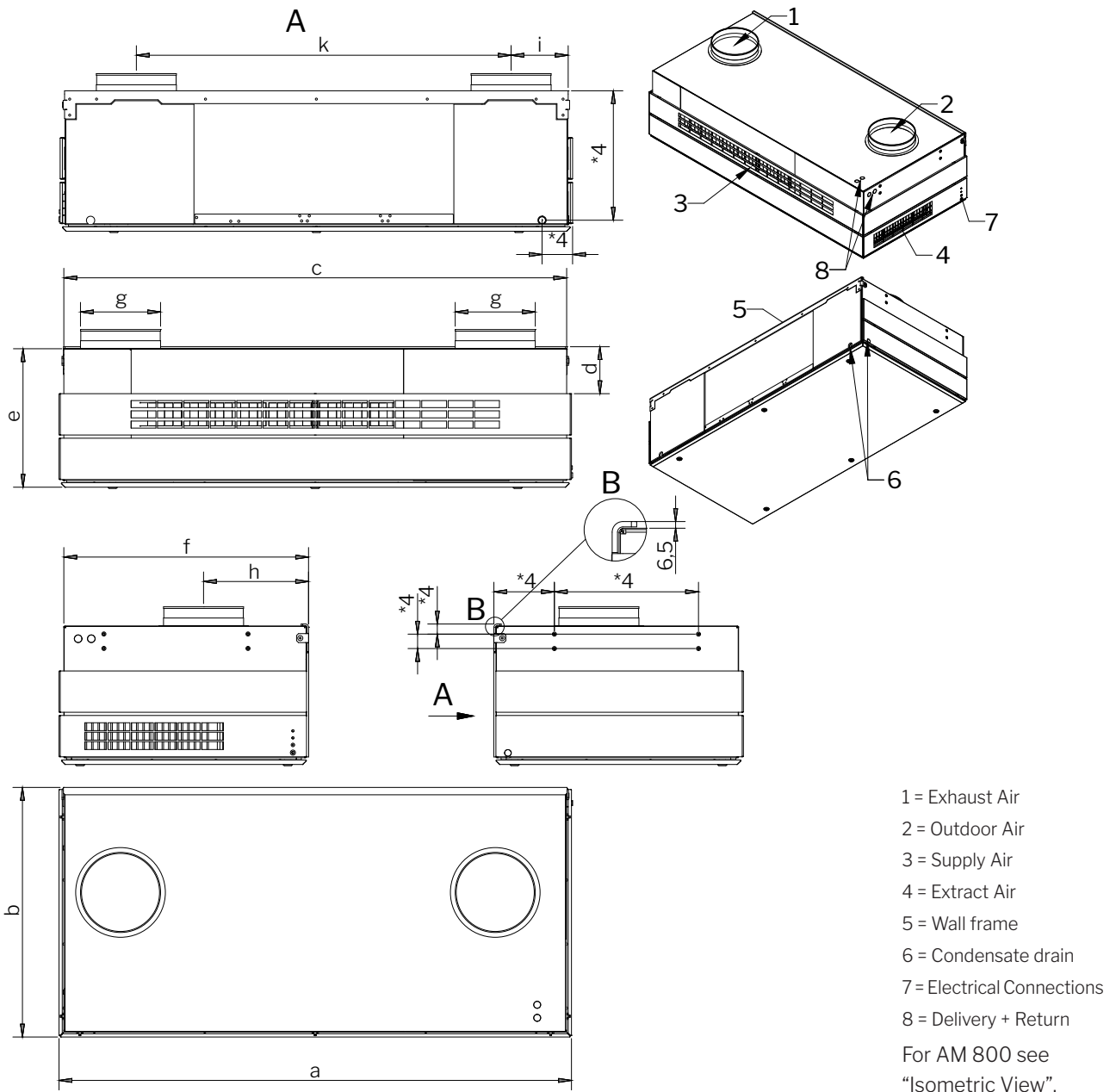

- 1 = Exhaust Air
  - 2 = Outdoor Air
  - 3 = Supply Air
  - 4 = Extract Air
  - 5 = Wall frame
  - 6 = Condensate drain
  - 7 = Electrical Connections
  - 8 = Delivery + Return
- For AM 800 see "Isometric View".

AM	a	b	c	d	e	f	g	h*1	i*2	k
500	1600	779	1570	147	432	764	250	328	178	1170
800	1910	915	1880	159	467	901	315	206	242	1457

\*1 Distance from the wall to centre hole.  
 \*2 Distance from left edge of wall frame to centre hole.  
 \*3 Distance from top edge of wall frame to centre hole.  
 \*4 See "Appendix 2 Additional Dimensions".

# AM 500 and 800 DIDE

Shown here: AM 500 HDIDE with Extract on the right side and three panel rows.

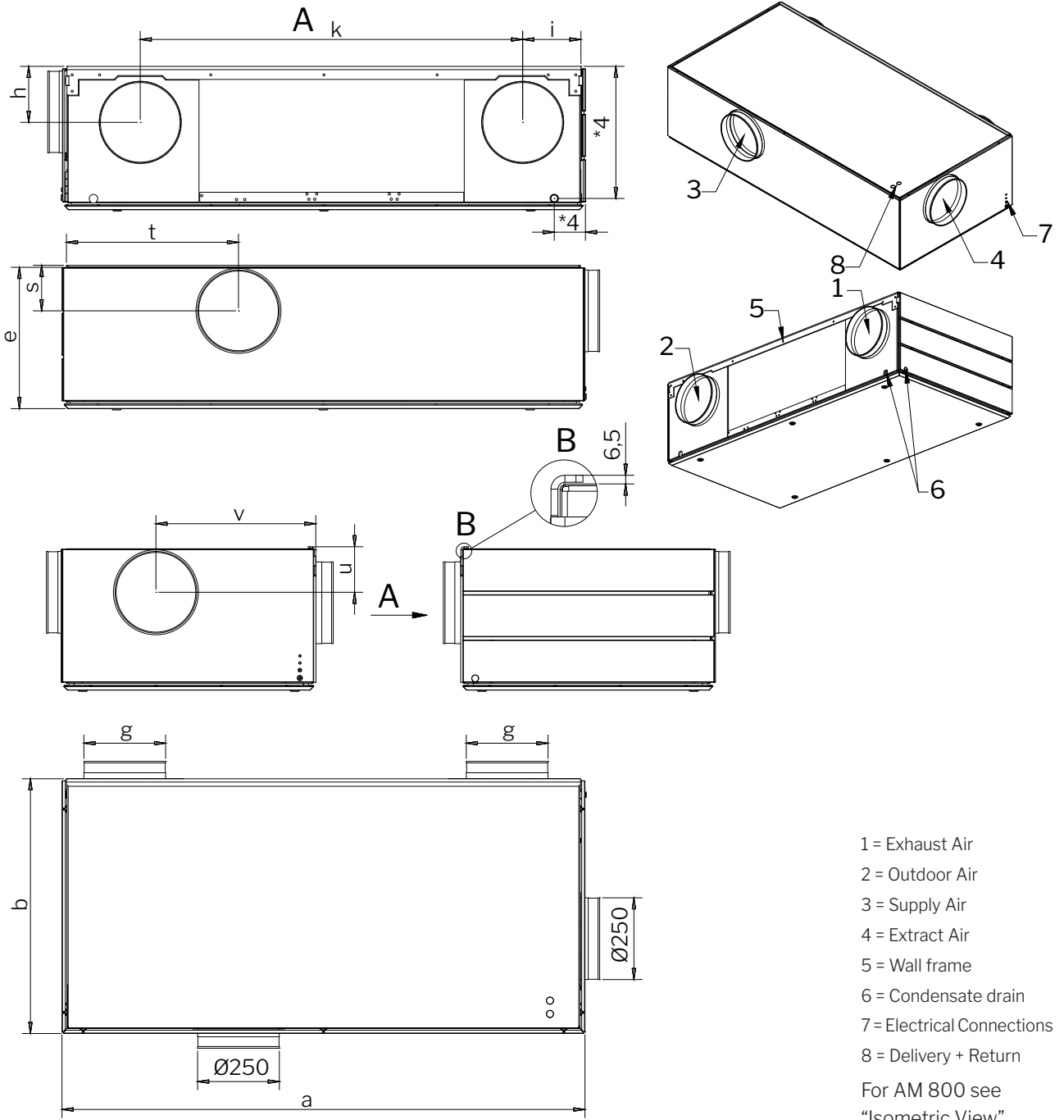

AM	a	b	e	g	h*1	i*2	k	s*1	t*2	u*1	v
500	1600	779	432	250	171	178	1170	139	526	139	489
800	1910	915	467	315	252	242	1433	*4	*4	*4	*4

\*1 Distance from top edge of wall frame to centre hole.

\*2 Distance from left edge of wall frame (without mounting pin) to centre hole.

\*4 See "Appendix 2 Additional Dimensions".

# AM 500 and 800 H - CF (Ceiling Frame)

Shown here: AM 500 HT - CF with Extract on the right side and three panel rows.

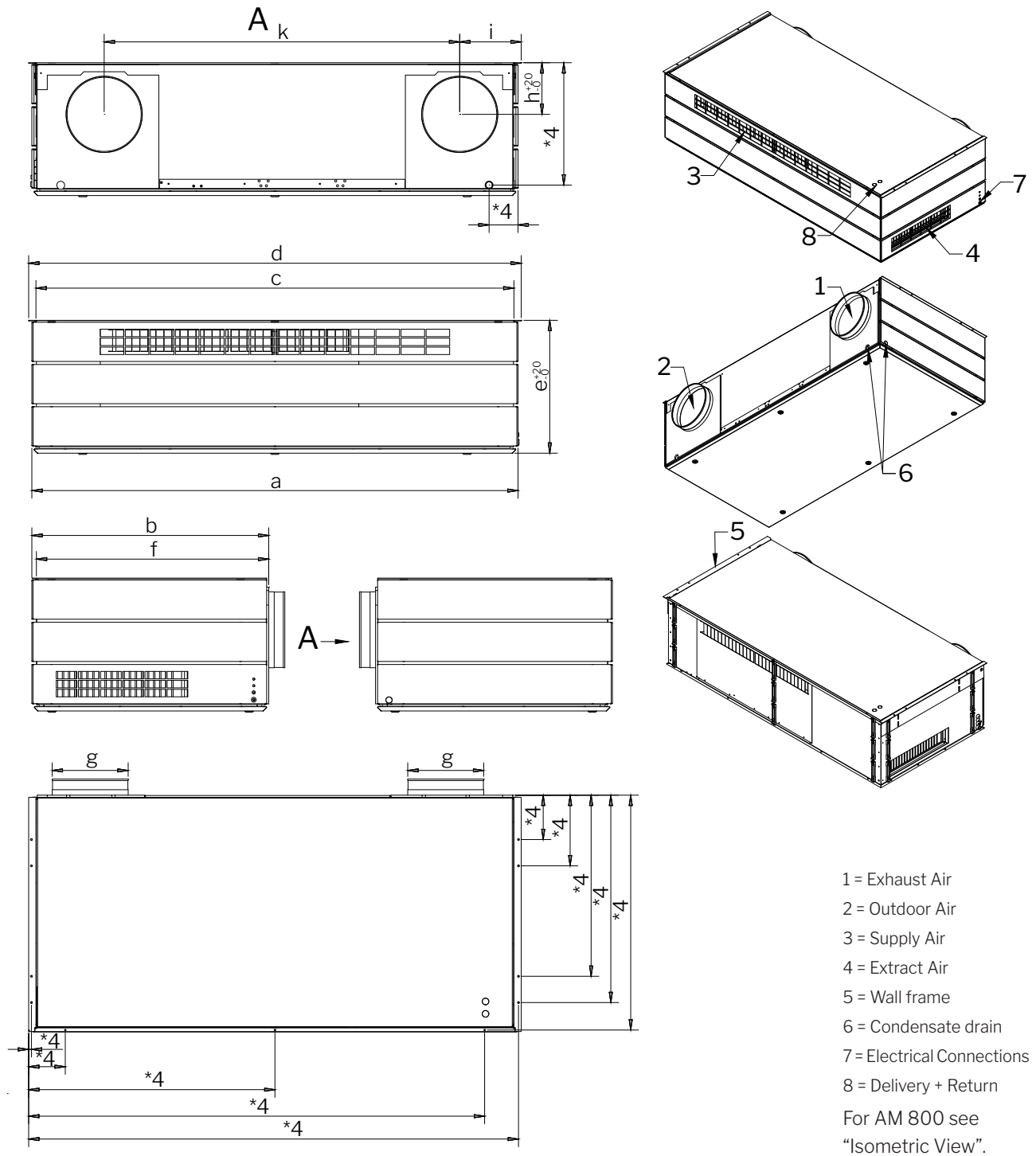

AM	a	b	c	d	e*1	f	g	h*1	i*2	k
500	1600	779	1570	1621	437	764	250	170	202	1170
800	1910	916	1880	1931	472	901	315	250	266	1433

\*1 Distance from the wall to centre hole. The vertical position of the handling unit can be adjusted up to +20/-0 mm.

\*2 Distance from left edge of ceiling frame to centre hole.

\*4 See "Appendix 2 Additional Dimensions".

# AM 500 and 800 V - CF (Ceiling Frame)

Shown here: AM 500 VT - CF with Extract on the right side and three panel rows.

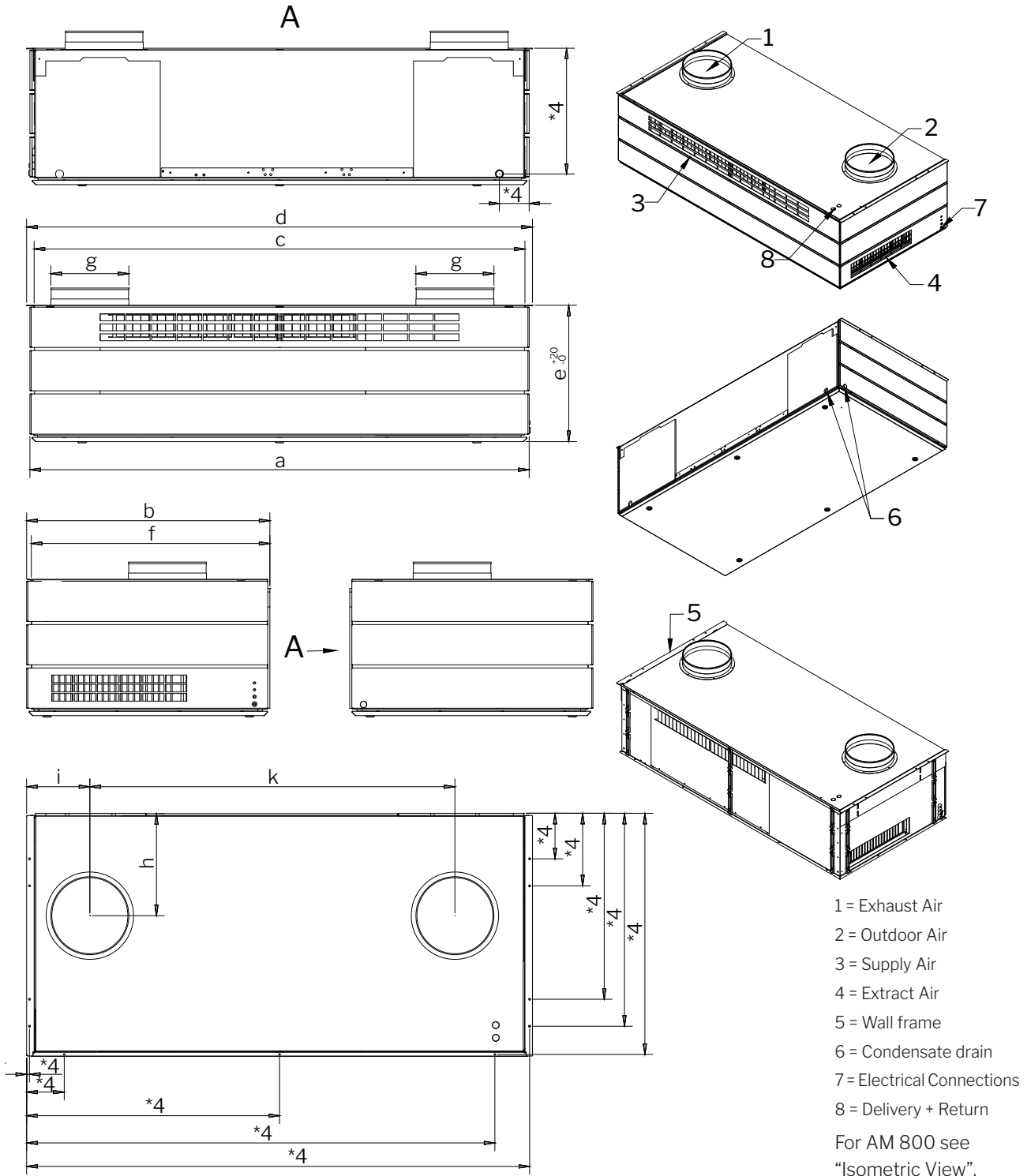

AM	a	b	c	d	e*1	f	g	h	i*2	k
500	1600	779	1570	1621	437	764	250	327	203	1170
800	1910	916	1880	1931	472	901	315	206	266	1457

\*1 Distance from the wall to centre hole. The vertical position of the handling unit can be adjusted up to +20/-0 mm.

\*2 Distance from left edge of ceiling frame to centre hole.

\*4 See "Appendix 2 Additional Dimensions".

# AM 500 and 800 H - CC (with Cooling Module)

Shown here: AM 500 HB-CC with Extract on the right side and one panel row.

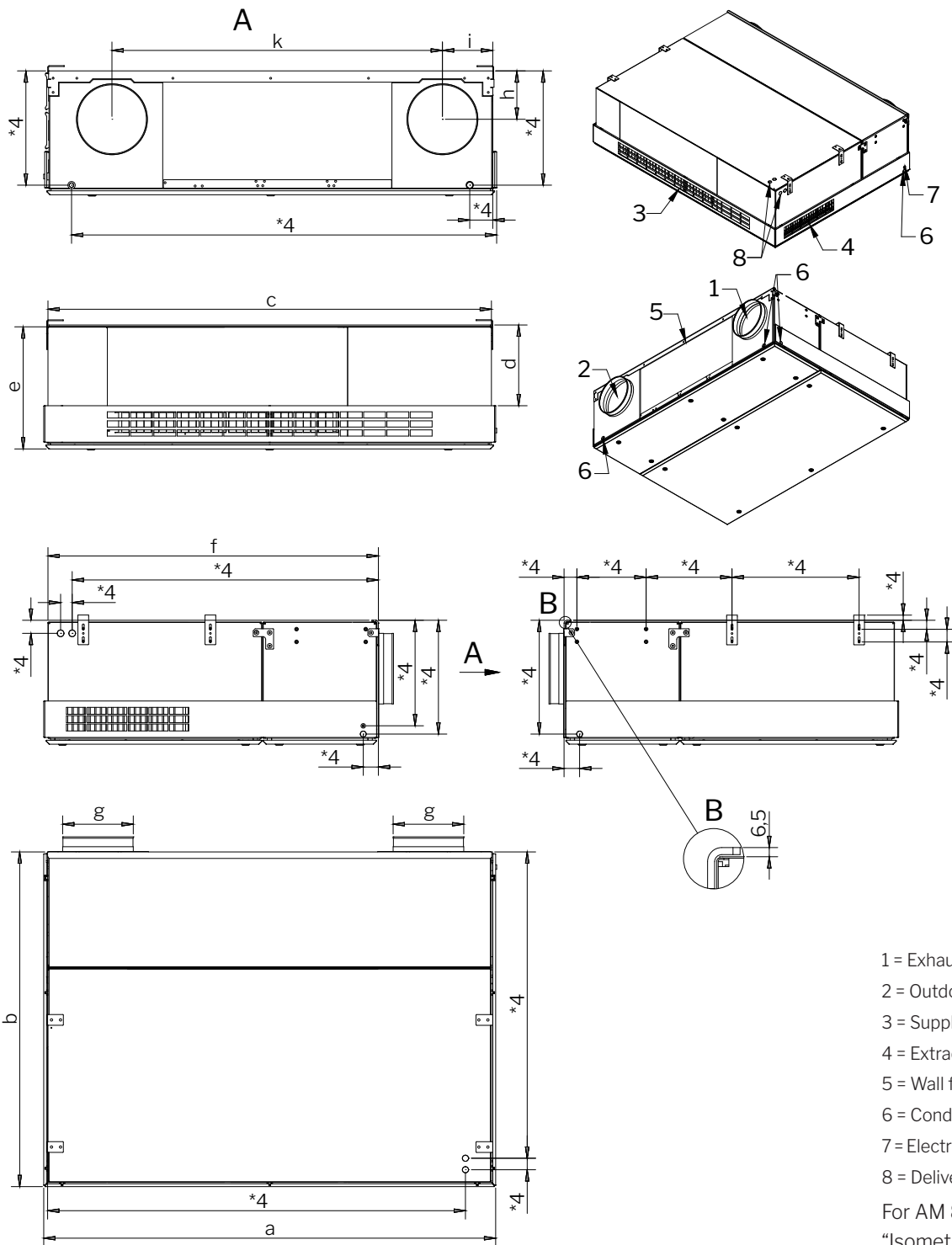

- 1 = Exhaust Air
  - 2 = Outdoor Air
  - 3 = Supply Air
  - 4 = Extract Air
  - 5 = Wall frame
  - 6 = Condensate drain
  - 7 = Electrical Connections
  - 8 = Delivery + Return
- For AM 800 see "Isometric View".

AM	a	b	c	d	e	f	g	h*1	i*2	k
500	1600	1185	1570	286	432	1170	250	171	178	1170
800	1910	1322	1880	310	467	1307	315	252	242	1433

\*1 Distance from top edge of wall frame to centre hole.  
 \*2 Distance from left edge of wall frame (without mounting pin) to centre hole.  
 \*4 See "Appendix 2 Additional Dimensions".

# AM 500 and 800 HDIDE - CC (with Cooling Module)

Shown here: AM 500 HDIDE-CC with Extract on the right side and three panel rows..

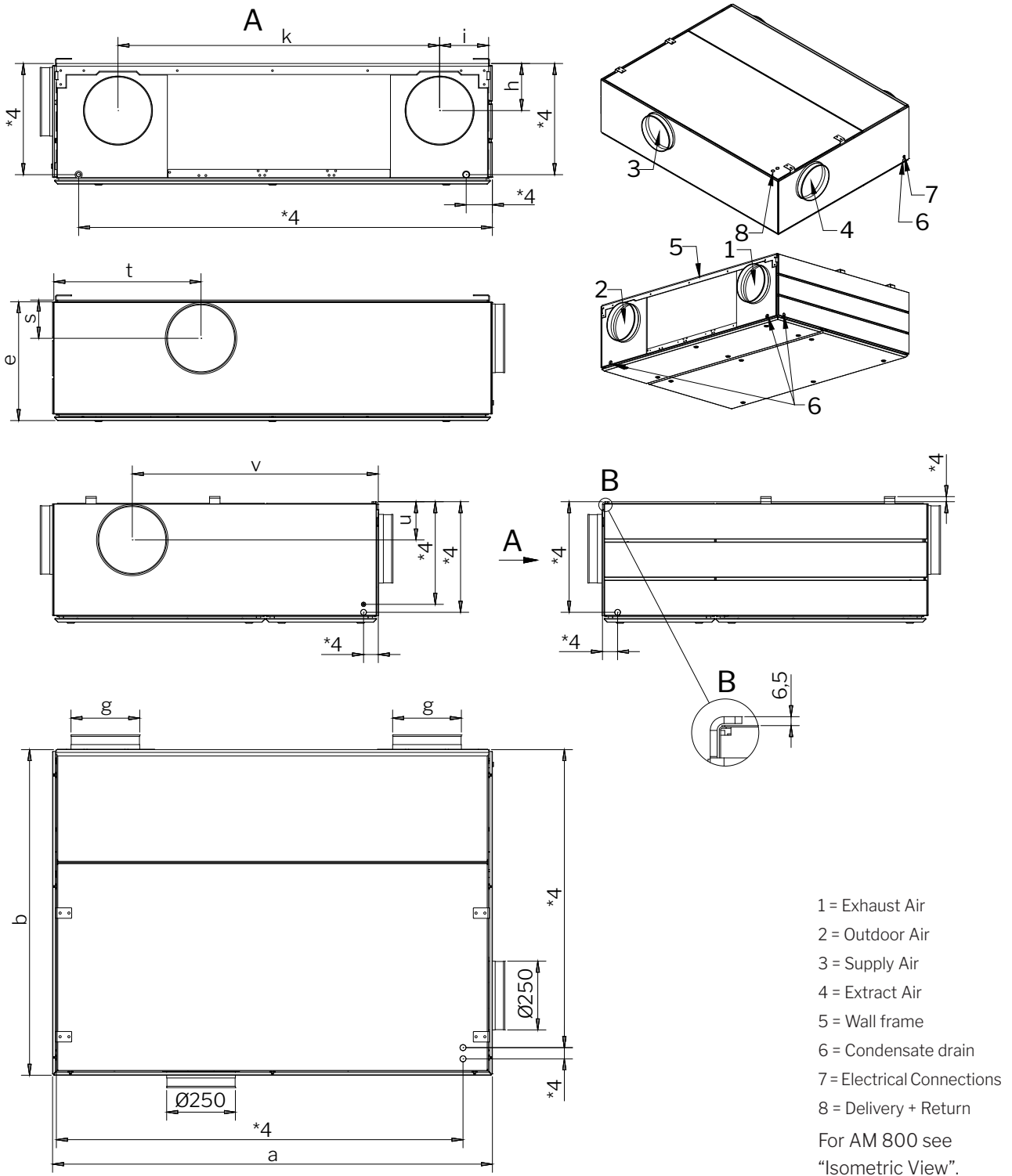

AM	a	b	e	g	h*1	i*2	k	s*1	t*2	u*1	v
500	1600	1185	432	250	171	178	1170	139	526	139	895
800	1910	1322	467	315	252	242	1433	*4	*4	*4	*4

\*1 Distance from top edge of wall frame to centre hole.  
 \*2 Distance from left edge of wall frame (without mounting pin) to centre hole.  
 \*4 See "Appendix 2 Additional Dimensions".



# Isometric View

AM 500H

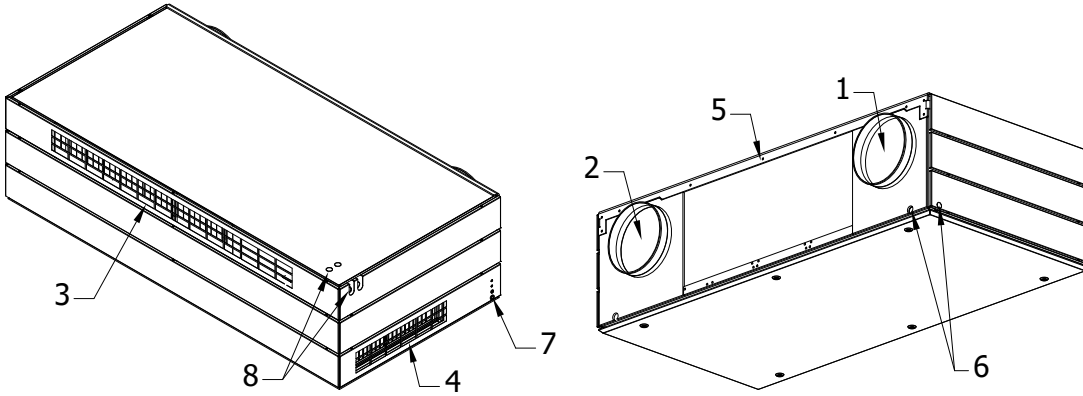

AM 500H DIDE

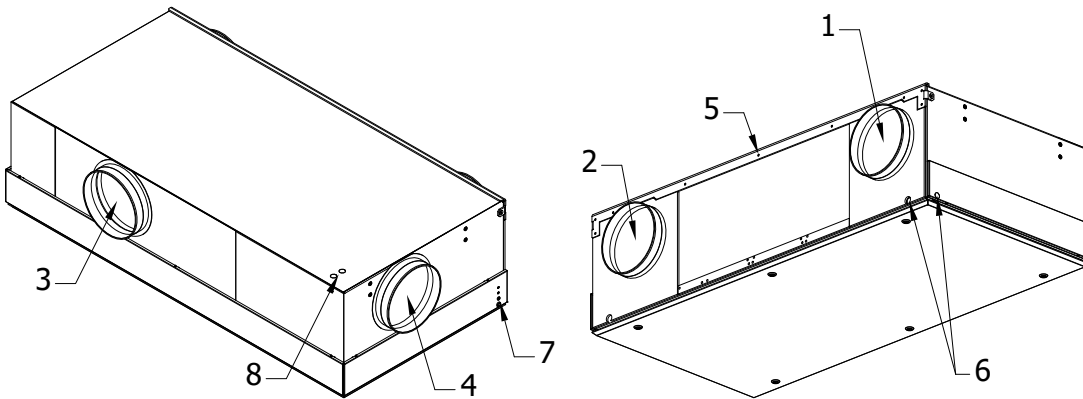

AM 800H

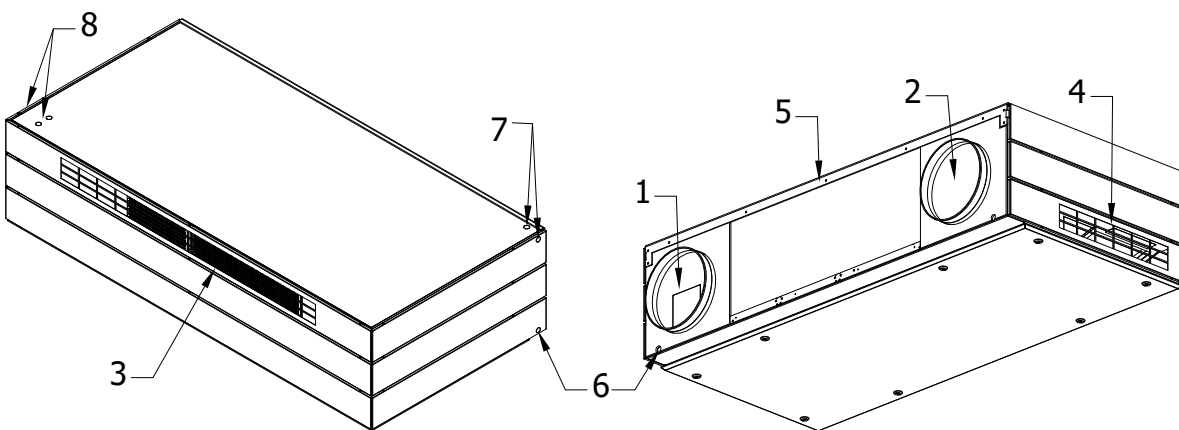

AM 800H DIDE

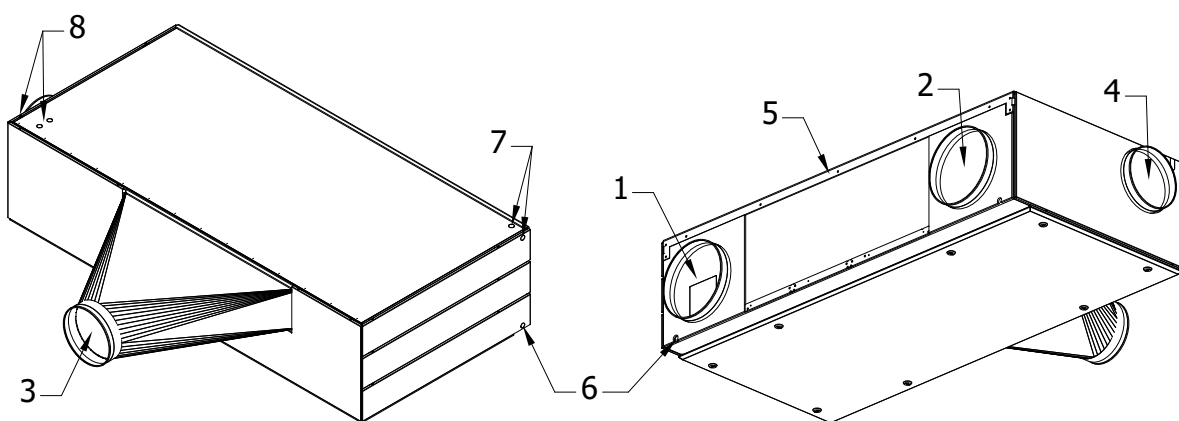

1 = Exhaust Air  
2 = Outdoor Air

3 = Supply Air  
4 = Extract Air

5 = Wall Frame  
6 = Condensate Drain

7 = Electr. Connection  
8 = Delivery + Return

AM 500V

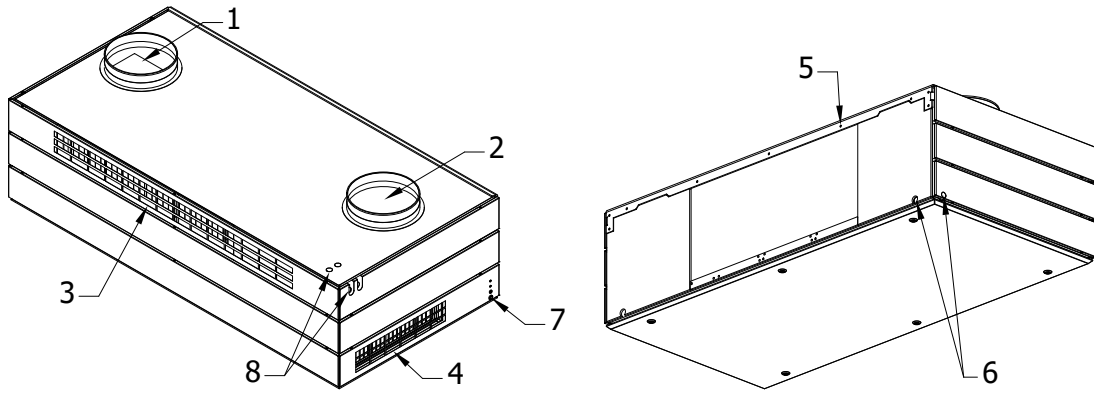

AM 500V DIDE

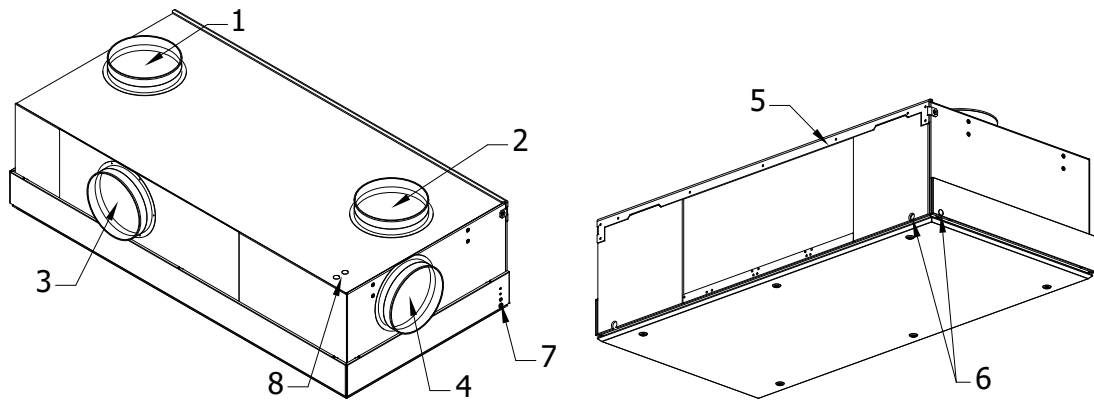

AM 800V

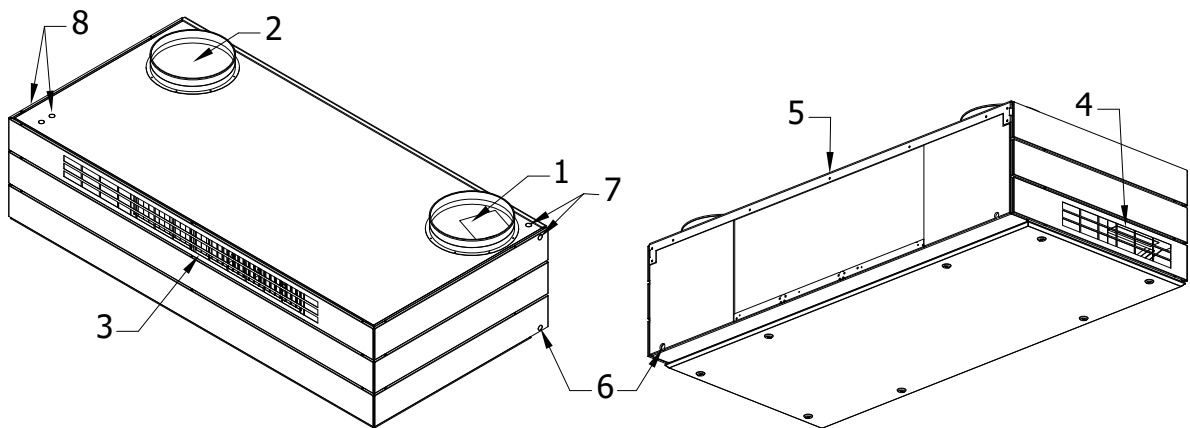

AM 800V DIDE

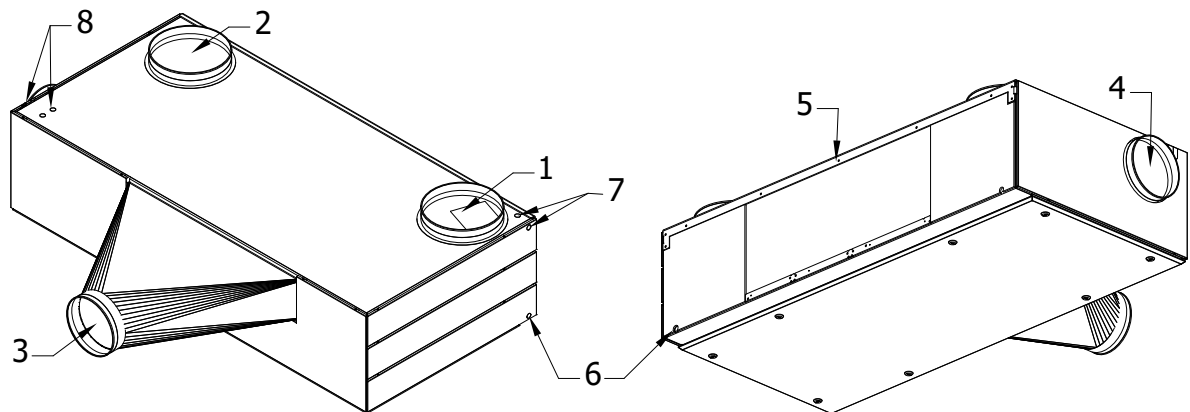

1 = Exhaust Air  
2 = Outdoor Air

3 = Supply Air  
4 = Extract Air

5 = Wall Frame  
6 = Condensate Drain

7 = Electr. Connection  
8 = Delivery + Return

AM 500 H - CF (Ceiling Frame)

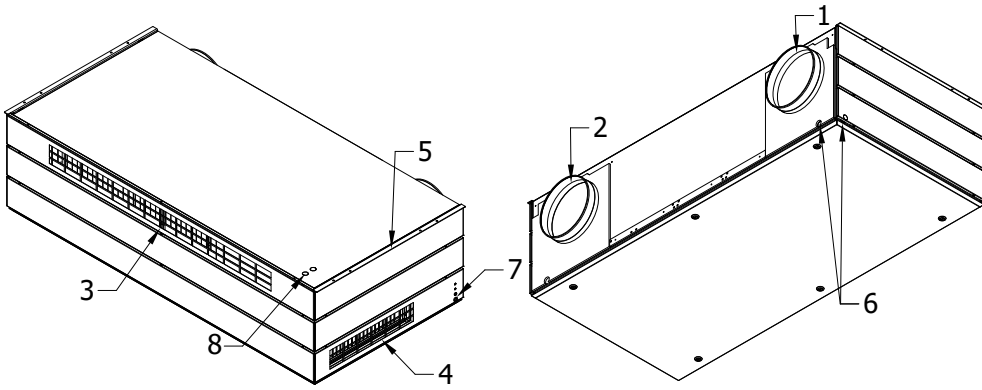

AM 500V - CF (Ceiling Frame)

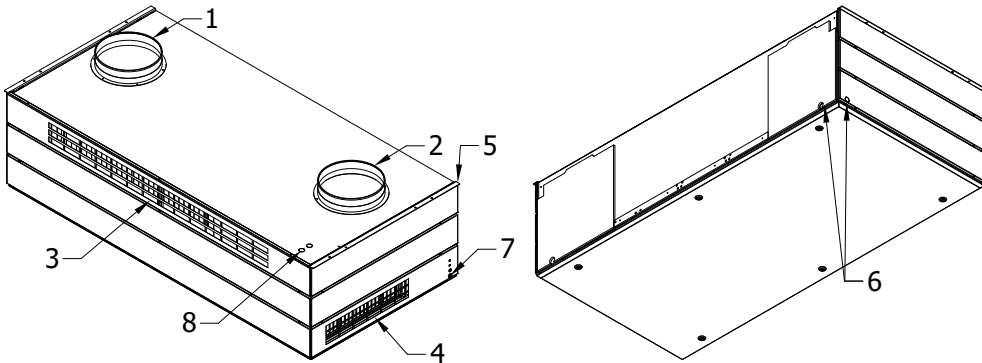

AM 800H - CF (Ceiling Frame)

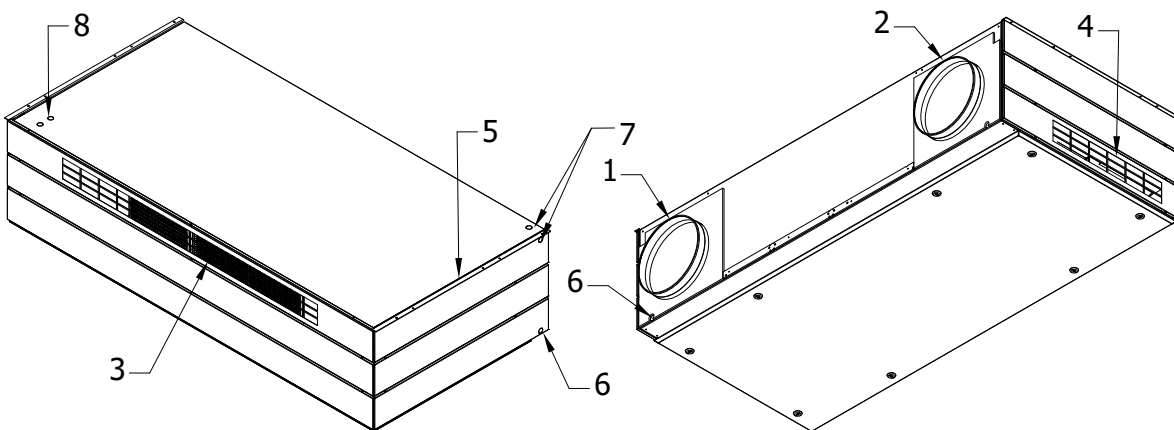

AM 800V - CF (Ceiling Frame)

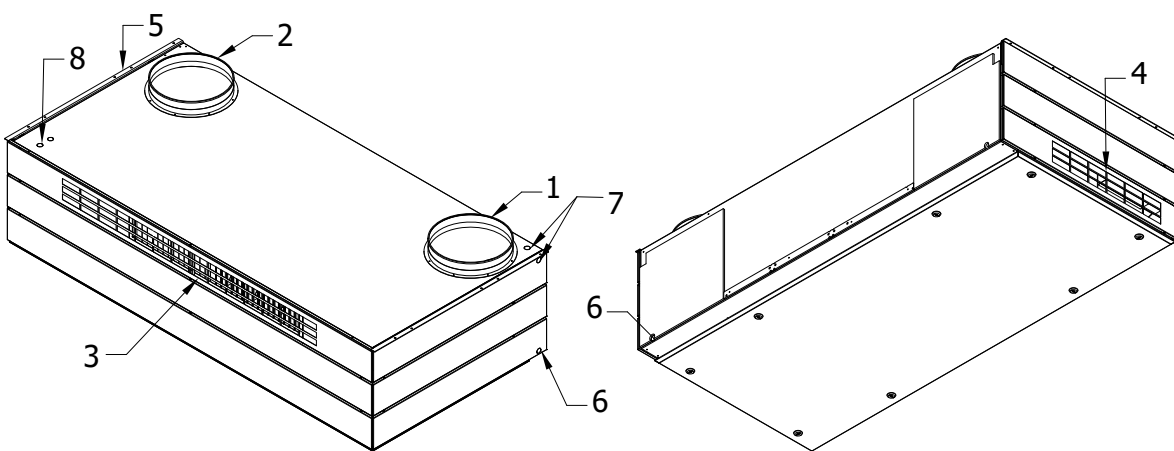

1 = Exhaust Air  
2 = Outdoor Air

3 = Supply Air  
4 = Extract Air

5 = Wall Frame  
6 = Condensate Drain

7 = Electr. Connection  
8 = Delivery + Return

AM 500 H - CC (with Cooling Module)

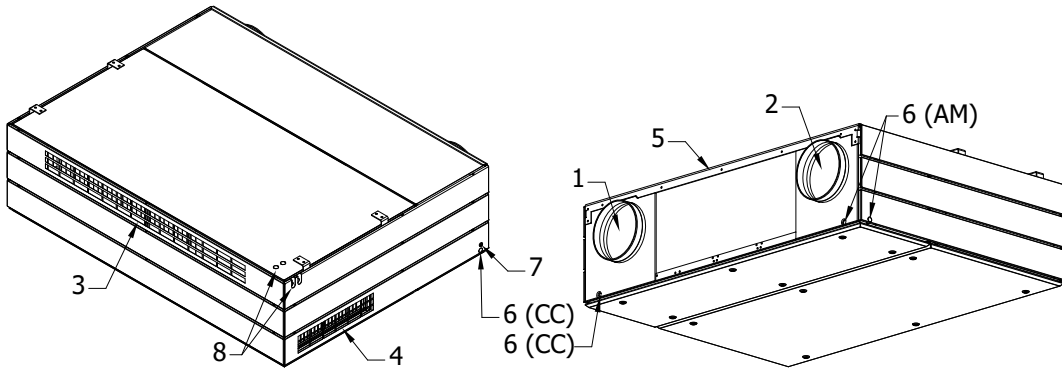

AM 800H - CC (with Cooling Module)

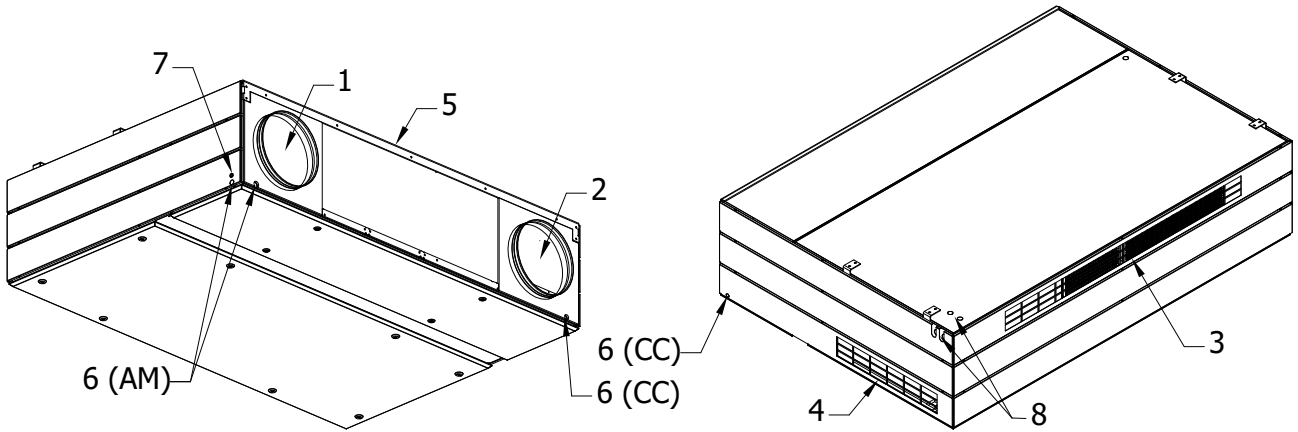

1 = Exhaust Air  
2 = Outdoor Air

3 = Supply Air  
4 = Extract Air

5 = Wall Frame  
6 = Condensate Drain

7 = Electr. Connection  
8 = Delivery + Return

## Model Versions AM 500 and 800

Version T: Supply air top.

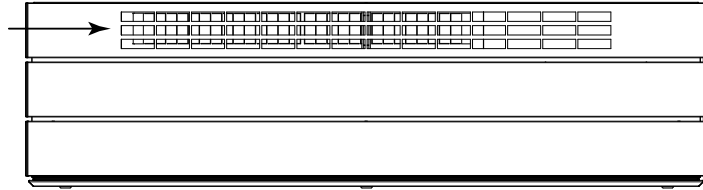

Version C: Supply air middle.

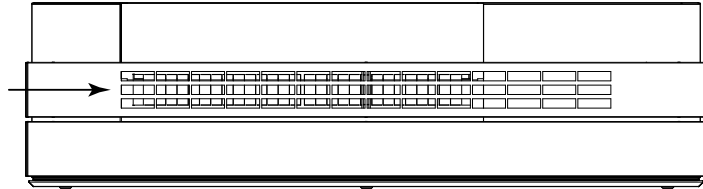

Version B: Supply air bottom.

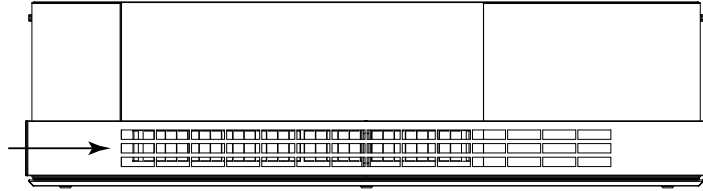

Version DI: Ducted supply air.

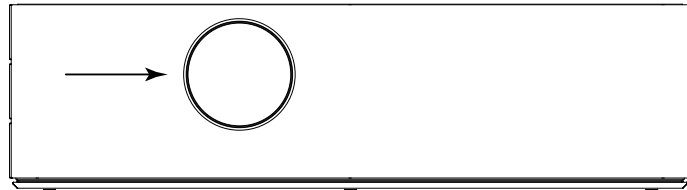

Version DE: Ducted extract air.

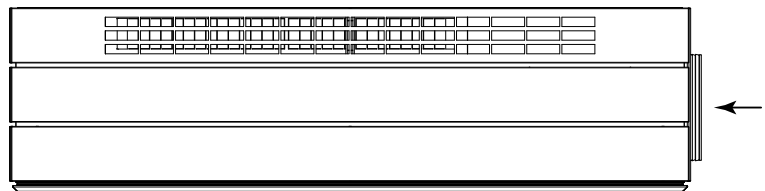

Version RE: Outdoor air and Exhaust air with square spigots.

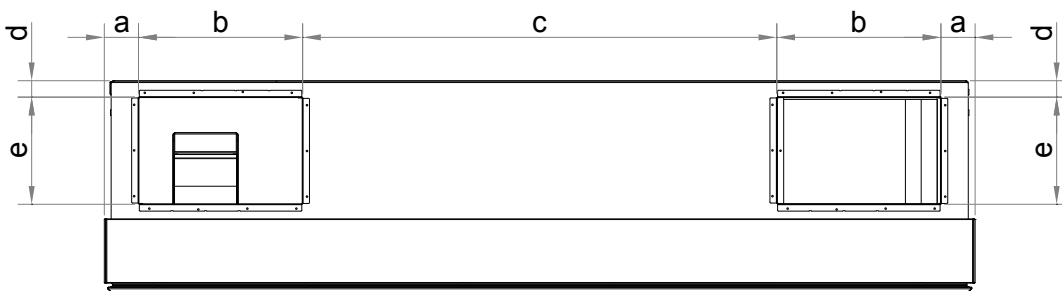

AM	a	b	c	d	e
500	65	250	940	41	200
800	75	360	1040	36	235

## Appendix 2 Additional Dimensions

### Connections AM 500

### Connections AM 500 - CF (Ceiling Frame)

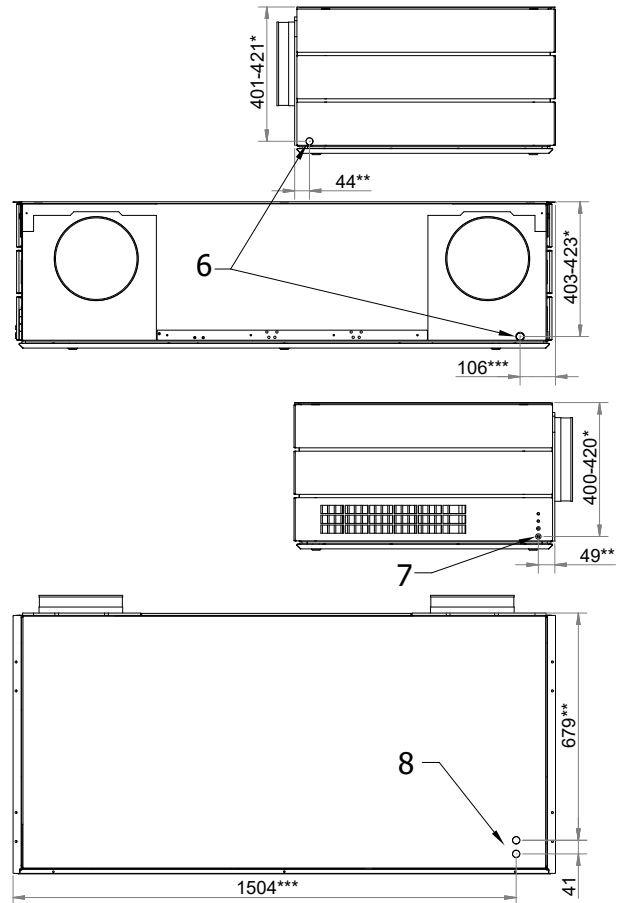
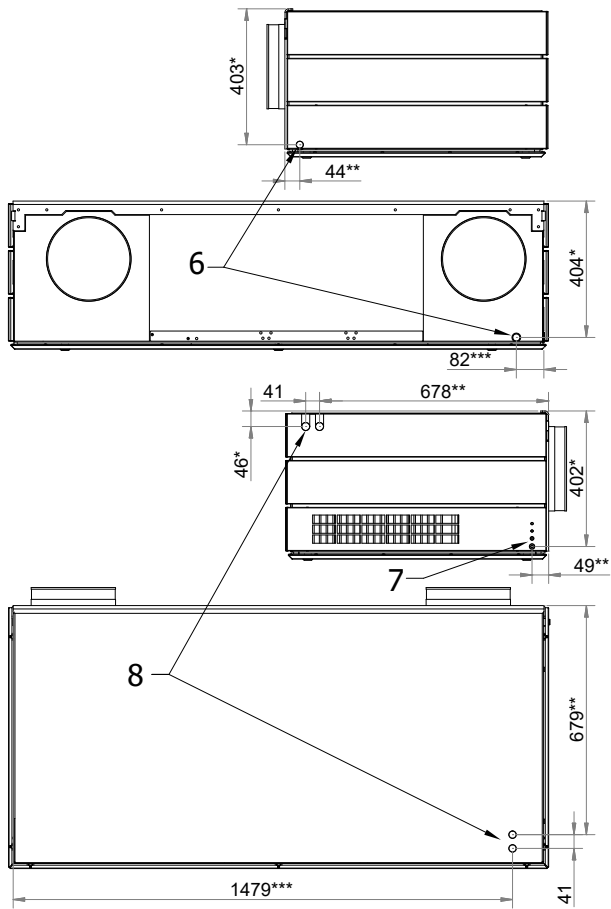

6 = Condensate Drain

7 = Electrical Connection

8 = Delivery + Return

AM 500: Delivery is towards the front.

\* From top edge of wall / ceiling frame.

\*\* From wall.

\*\*\* From left edge of wall / ceiling frame.

### Connections AM 500 - CC

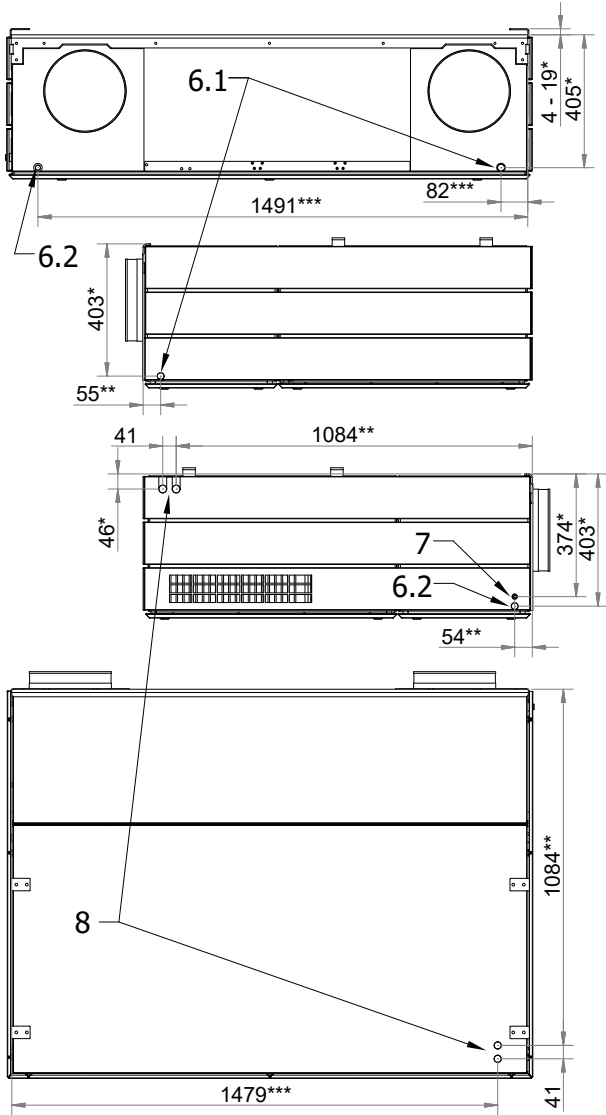

### Connections AM 800

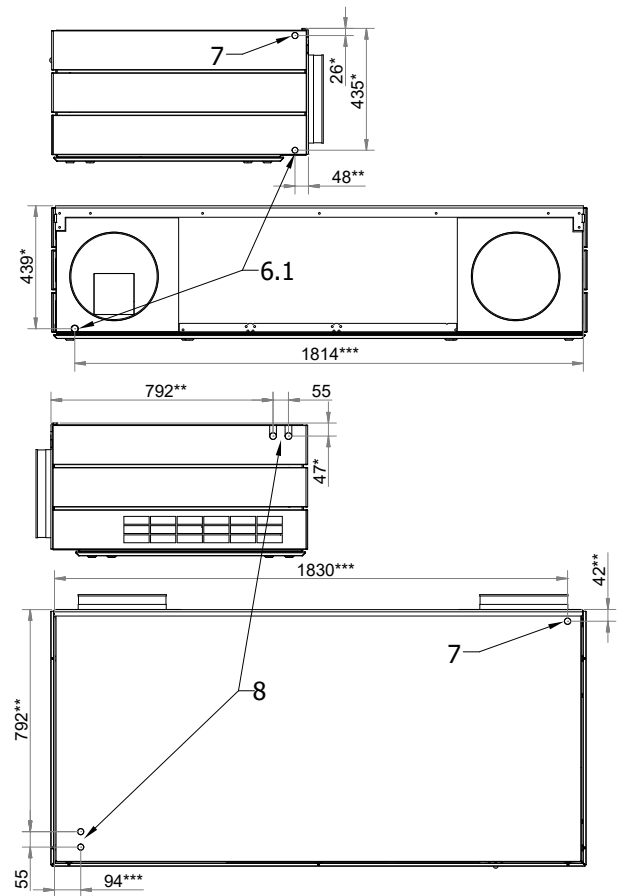

### Connections AM 800 - CF (Ceiling Frame)

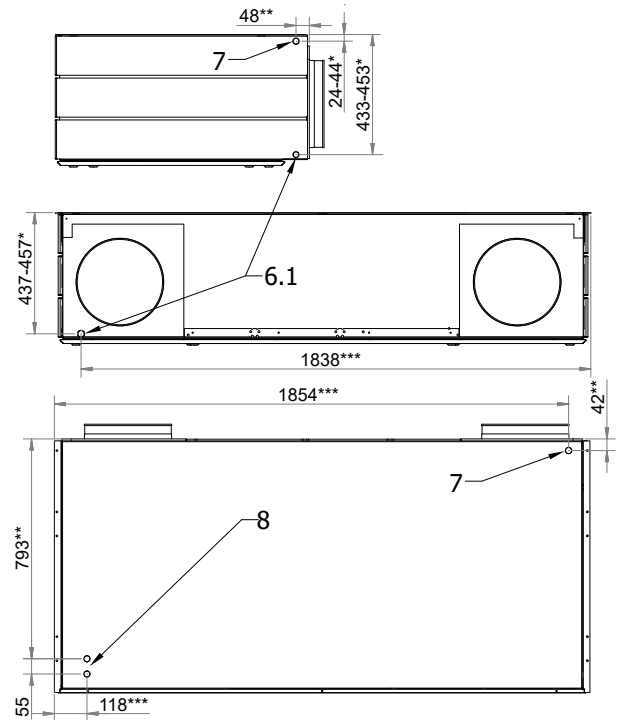

6.1 = Condensate Drain AM

6.2 = Condensate Drain CC

7 = Electrical Connection

8 = Delivery + Return

AM 500: Delivery is towards the front.

AM 800: Return is towards the front.

\* From top edge of wall / ceiling frame.

\*\* From wall.

\*\*\* From left edge of wall / ceiling frame.

## Connections AM 800 DIDE

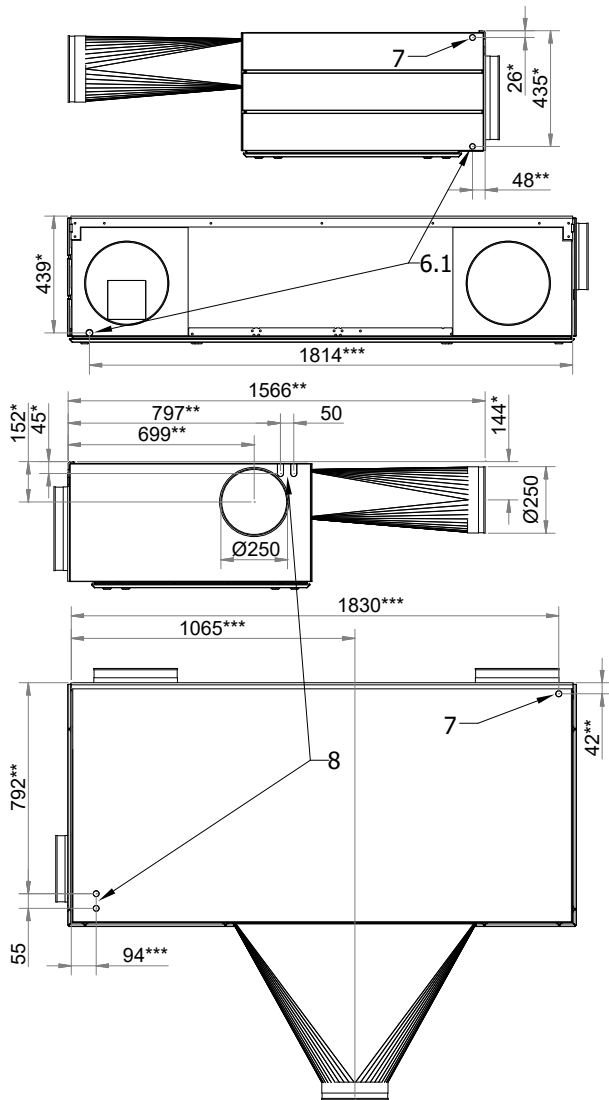

## Connections AM 800 - CC

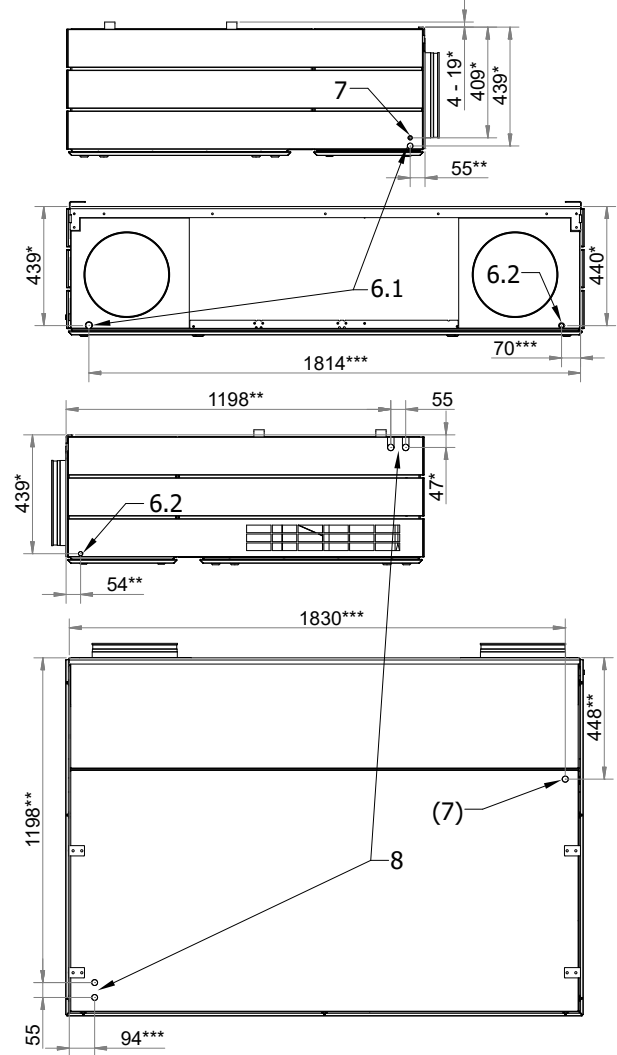

6.1 = Condensate Drain AM

6.2 = Condensate Drain CC

7 = Electrical Connection

8 = Delivery + Return

AM 800: Return is towards the front.

\* From top edge of wall / ceiling frame.

\*\* From wall.

\*\*\* From left edge of wall / ceiling frame.



### Connections AM 800 DIDE - CC

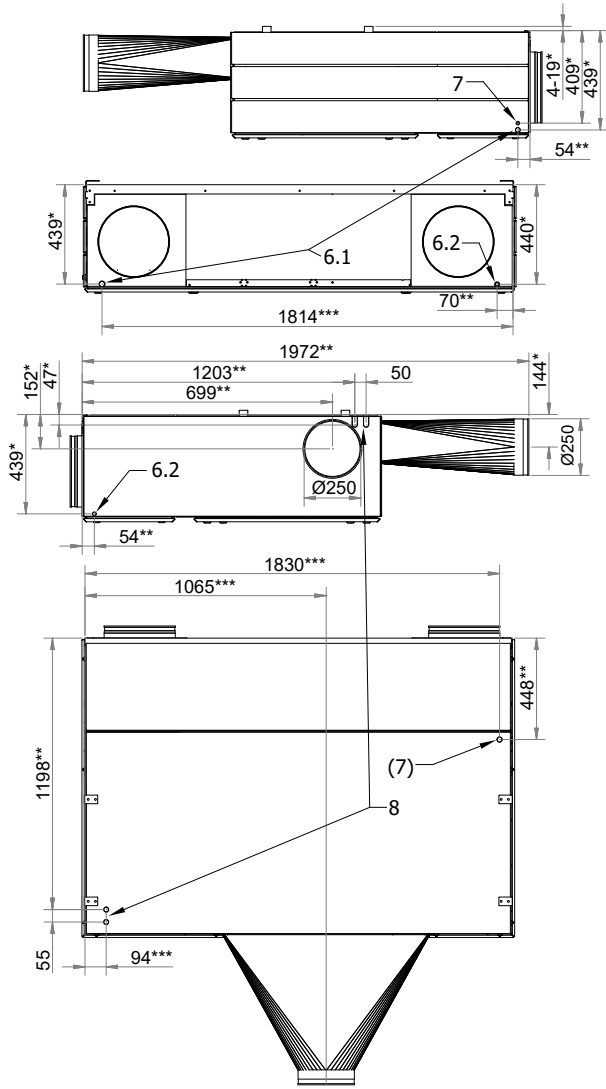

### Ceiling Bracket, Angle

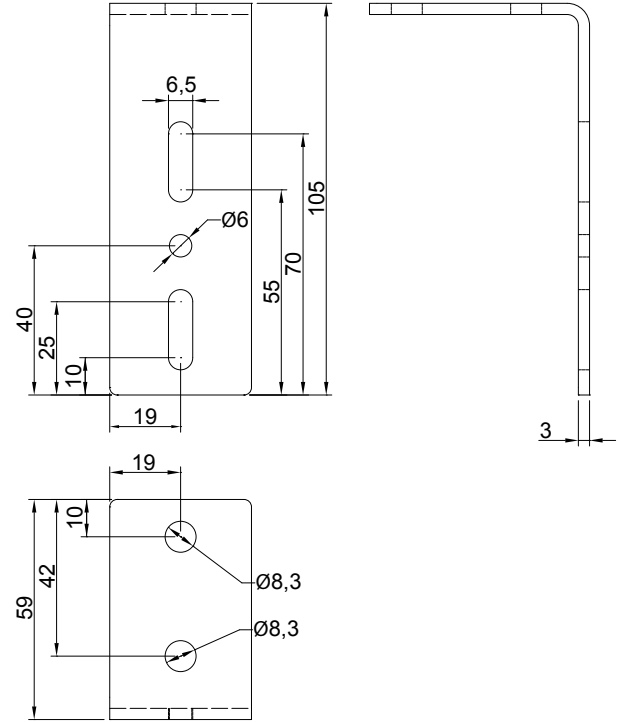

### Ceiling Bracket, Adjustable

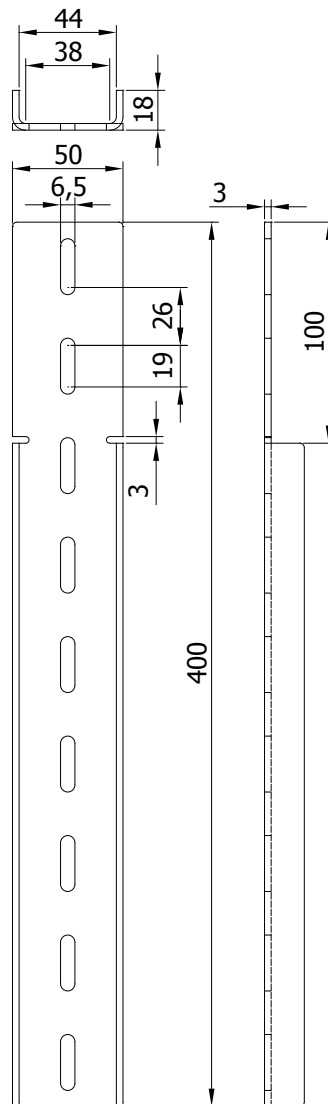

- 6.1 = Condensate Drain AM
  - 6.2 = Condensate Drain CC
  - 7 = Electrical Connection
  - 8 = Delivery + Return
- AM 800: Return is towards the front.

\* From top edge of wall / ceiling frame.  
 \*\* From wall.  
 \*\*\* From left edge of wall / ceiling frame.

## Positioning of the Ceiling Brackets

### AM 500 and 800

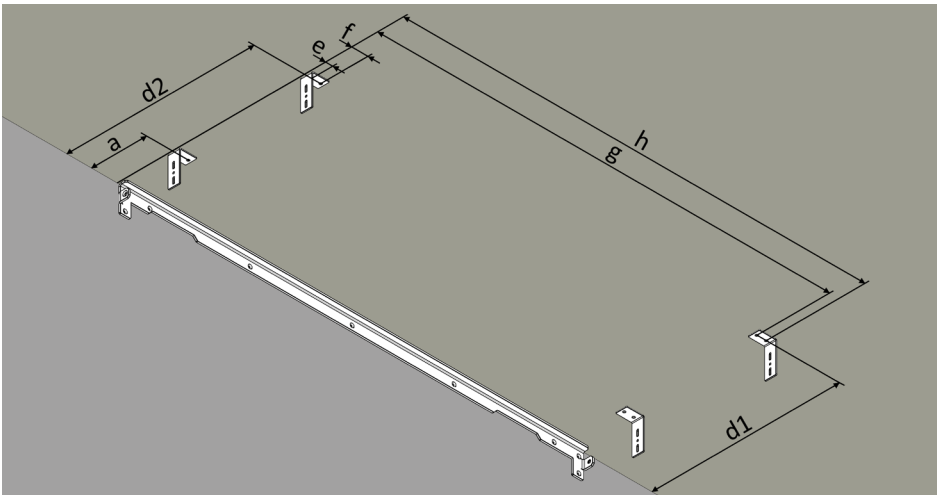

AM	Distance (A) wall frame to ceiling		Optical distance unit to ceiling		a**	d1**	d2**	e***	f***	g***	h***
	min.	max.	min.	max.							
500	4	19	11,5	26,5	189	639	639	15,5	47,5	1525,5	1557,5
800	3,5	18,5	11	26	306	756	756	15,5	47,5	1835,5	1867,5
800 (DE)	3,5	18,5	11	26	306	756	551	15,5	47,5	1835,5	1867,5

### AM 500 and 800 with Cooling Module (CC)

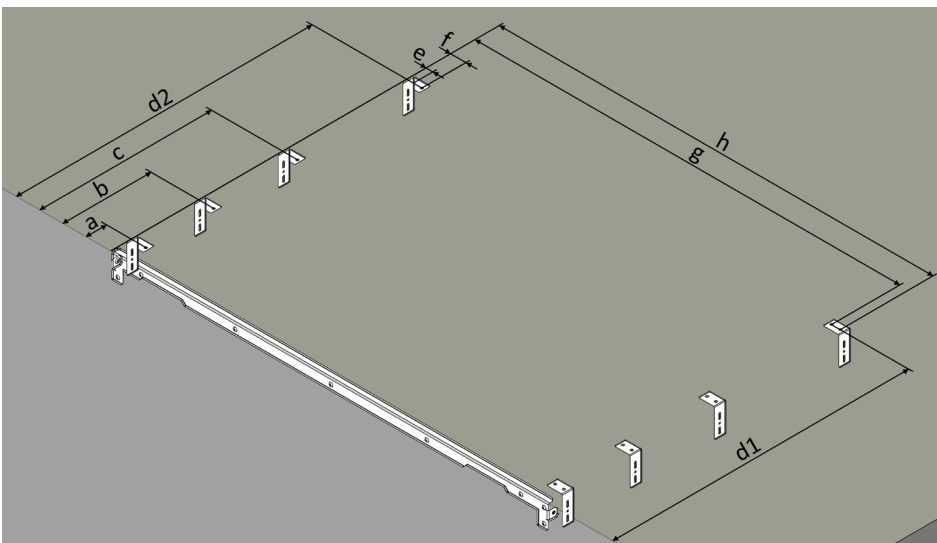

AM+CC	Distance (A) wall frame to ceiling		Optical distance unit to ceiling		a**	b**	c**	d1**	d2**	e***	f***	g***	h***
	min.	maks.	min.	maks.									
500	4	19	11,5	26,5	46	291	595	1045	1045	15,5	47,5	1525,5	1557,5
800	3,5	18,5	11	26	45	290	712	1162	1162	15,5	47,5	1835,5	1867,5
800 (DE)	3,5	18,5	11	26	45	290	712	1162	957	15,5	47,5	1835,5	1867,5

\*\* From wall.

\*\*\* From left edge of wall frame.

(DE) Version DE - Ducted extract.

## Positioning of the Ceiling Frame

### AM 500 and 800

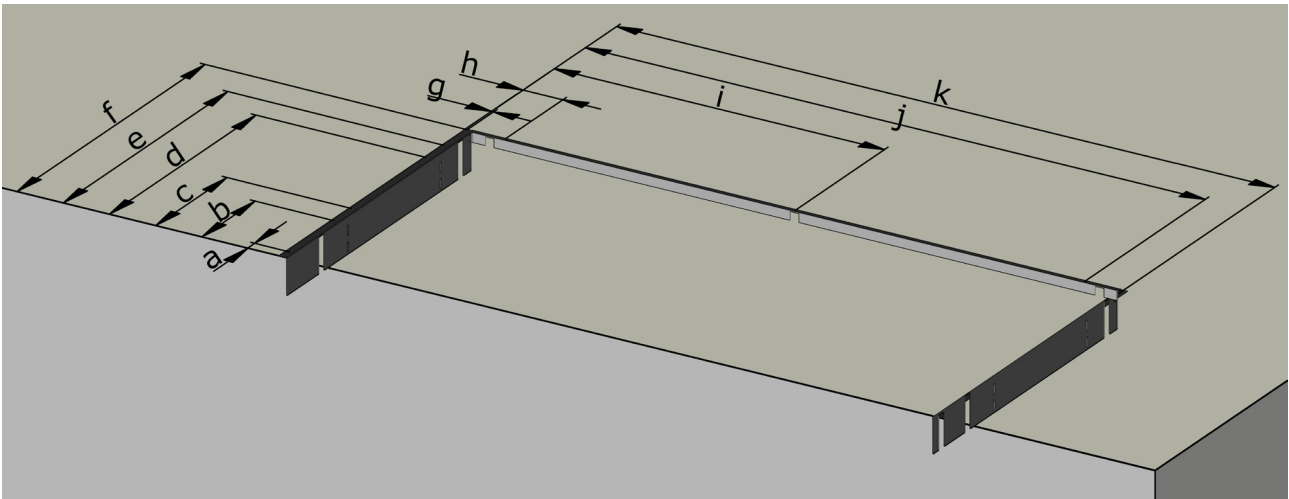

AM	a**	b**	c**	d**	e**	f**	g***	h***	i***	j***	k***
500	-	145	232	595	682	772	9	121	811	1501	1612
800	42	263	350	713	800	910	9	121	966	1811	1922

\*\* From wall.

\*\*\* From left edge of ceiling frame.

# AIRMASTER

Airmaster A/S  
Industrivej 59  
DK-9600 Aars

Tel.: +45 98 62 48 22  
info@airmaster-as.com  
www.airmaster-as.com