

Data Sheet AM 150 / CC 150

Technical data	Filter class	30 dB(A)	35 dB(A)	Boost
Maximum capacity ¹	ePM ₁₀ 50%	106 m ³ /h	146 m ³ /h	225 m ³ /h
	ePM ₁ 55%	84 m ³ /h	117 m ³ /h	206 m ³ /h
	ePM ₁ 80%	80 m ³ /h	108 m ³ /h	190 m ³ /h
Throw (0,2 m/s) ²	ePM ₁₀ 50%	2,4 m	3,4 m	4,6 m
	ePM ₁ 55%	2,0 m	2,7 m	4,2 m
	ePM ₁ 80%	1,9 m	2,5 m	3,8 m
Supply air filter	ePM ₁₀ 50%, ePM ₁ 55% or ePM ₁ 80%			
Extract air filter	ePM ₁₀ 50%			
Dimensions (WxHxD): AM 150+CC 150 / CC 150	1170 x 261 x 862 mm / 1170x261x290 mm			
Weight, standard unit, complete (AM 150 + CC 150)	82 kg (53 kg + 29 kg)			
Weight, casing (AM 150 + CC 150)	60 kg (40 kg + 20 Kg)			
Weight, service cover (AM 150 + CC 150)	22 kg (13 kg + 9 kg)			
Colour, casing	RAL 9010 (white)			
Counterflow heat exchanger	PET (Polyethylene terephthalate)			
Energy class, cf. EU regulation no. 1254	SEC class A			
Air leakage classification cf. EN1886/EN13141-7	Class L1 / Class A1			
Air leakage classification, main damper, cf. EN1751	Class 3			
IP code	10			
Duct connection	Ø160 mm			
Condensate pump (capacity/lifting height at 5 l/h)	10 l/h / 6 m			
Condensate drain hose int./ext. diameter	Ø4 mm / Ø6 mm			
Supply voltage	220-240V/50Hz, ~1N+PE			
Maximum power consumption	373 W			
Maximum current	1,62 A			
Power factor	0,55			
Maximum fuse	13 A (1 phase, type B). When using the cc module, it is type C			
Leakage current AC (AM; CC) / DC	≤ 0,52 mA ; ≤ 1,5 mA / ≤ 0,0007 mA			
Recommended residual current circuit breaker (RCCB)	Type B			

AM 150 + CC 150 cooling module

Energy class, cf. EU regulation no. 626/2011	SEC class A+++
Nominal ; min. cooling duty ⁴	700 W ; 146 W
Nominal EER	4,3
Max. ; nominal power consumption	249 W ; 162 W
Max. ; nominal current	1,84 A ; 1,1 A
Minimum airflow for activating the cooling module	50 m ³ /h
Refrigerant ; filling ; GWP	R134a ; 180g ; 1430

Electrical heating surfaces

Heat output	500 W	1000 W ³
Nominal current	2,17 A	4,35 A
Thermal circuit breaker, manual reset	100 °C	100 °C

¹ All measurements were performed in normal operating mode in a standard installation using the facade grills recommended by Airmaster, in a test room dimensioned 4.0 m x 4.0 m x 2.5 m with room attenuation of 7.5 dB. For larger rooms, e.g. 8.0 m x 10.0 m x 2.5 m, 2 dB must be deducted, i.e. sound pressure level for 2 dB higher can be used.

² The throw is measured with a 2 °C subcooled supply air at the standard setting of the inlet diffuser. The setting is adaptable, see page 7.

³ Special item

⁴ Cf. EN 308, EN 14511 and EN 14825 at 147 m³/h ; 50 m³/h.

Capacity⁵ with ePM₁₀ 50% / ePM₁₀ 50% filters

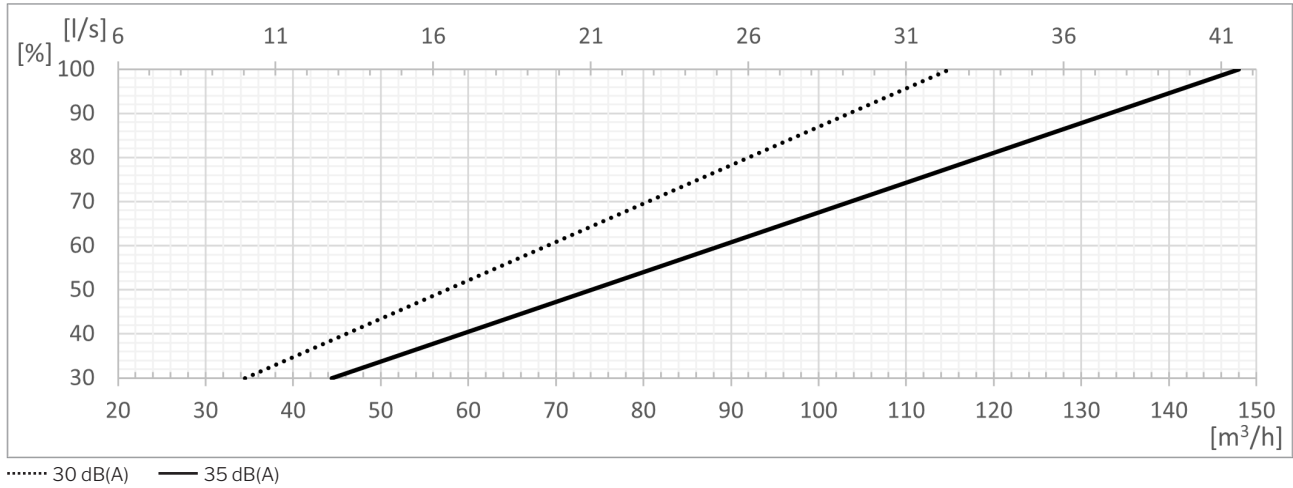

Capacity⁵ with ePM₁ 55% / ePM₁₀ 50% filters

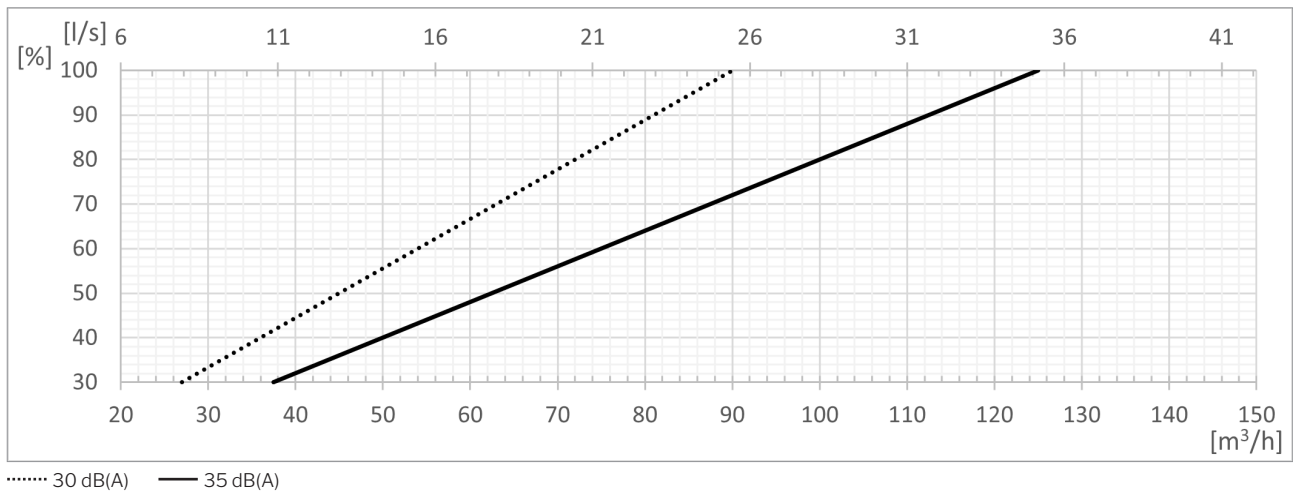

Capacity⁵ with ePM₁ 80% / ePM₁₀ 50% filters

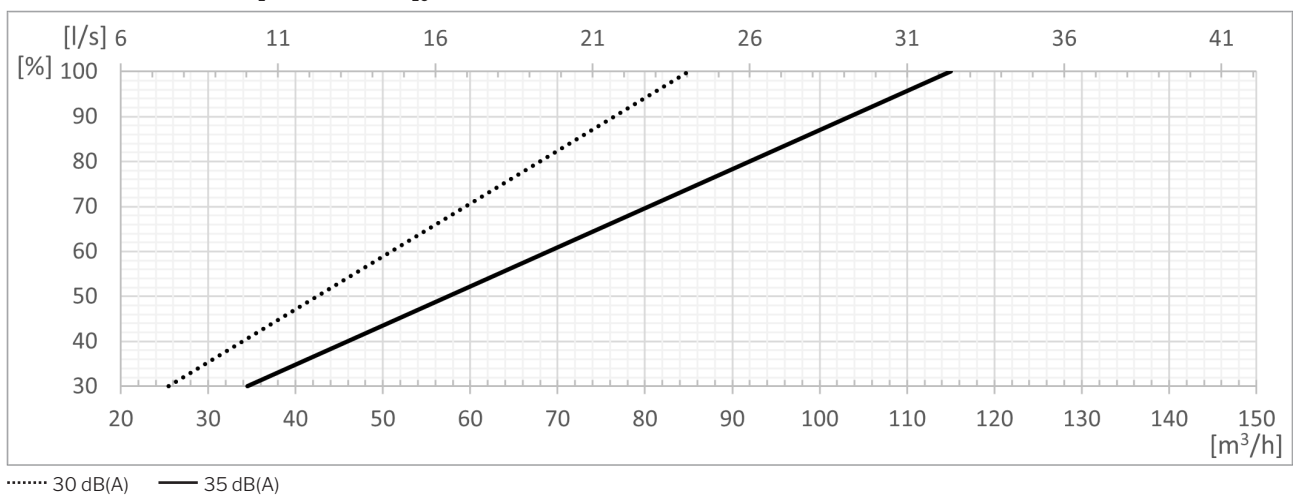

⁵ Minimum airflow for activating the cooling module : 50 m³/h.

SFP with ePM₁₀ 50% / ePM₁₀ 50% filters

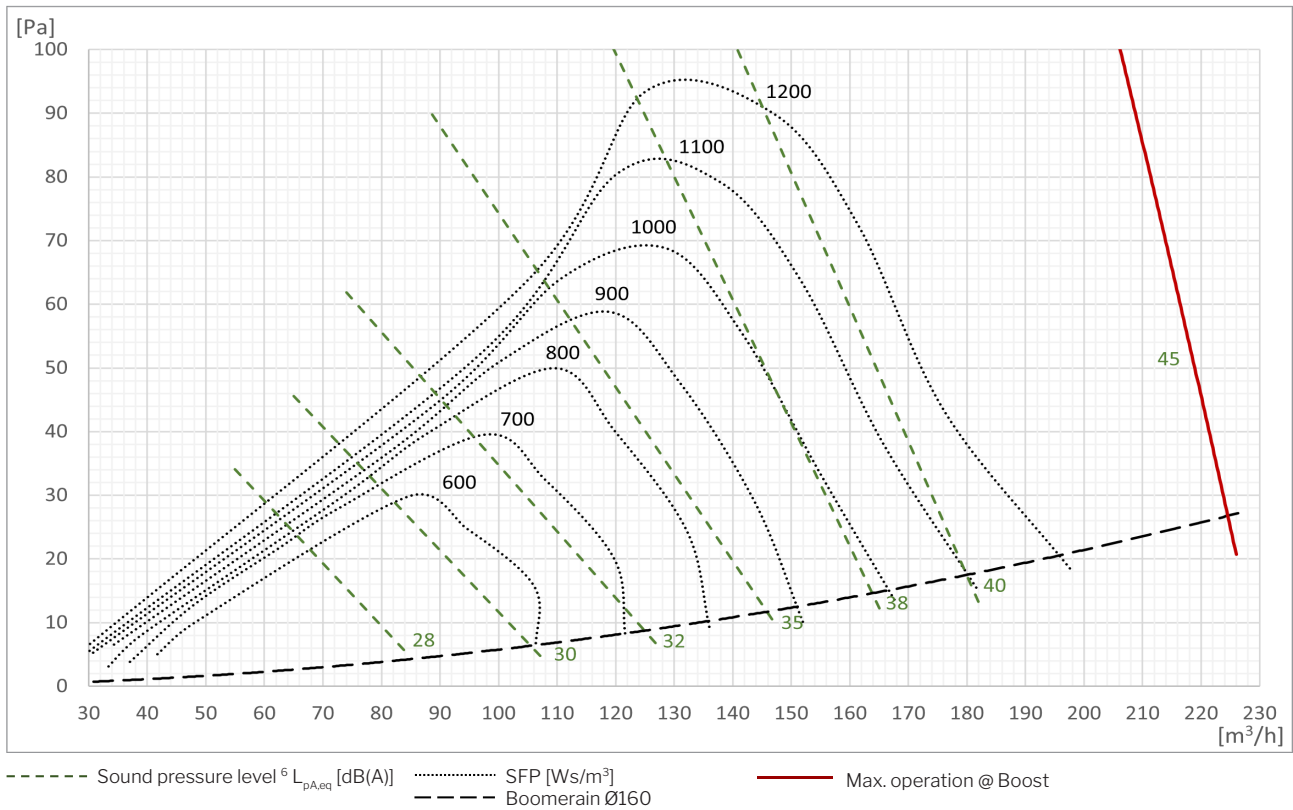

SFP with ePM₁ 55% / ePM₁₀ 50% filters

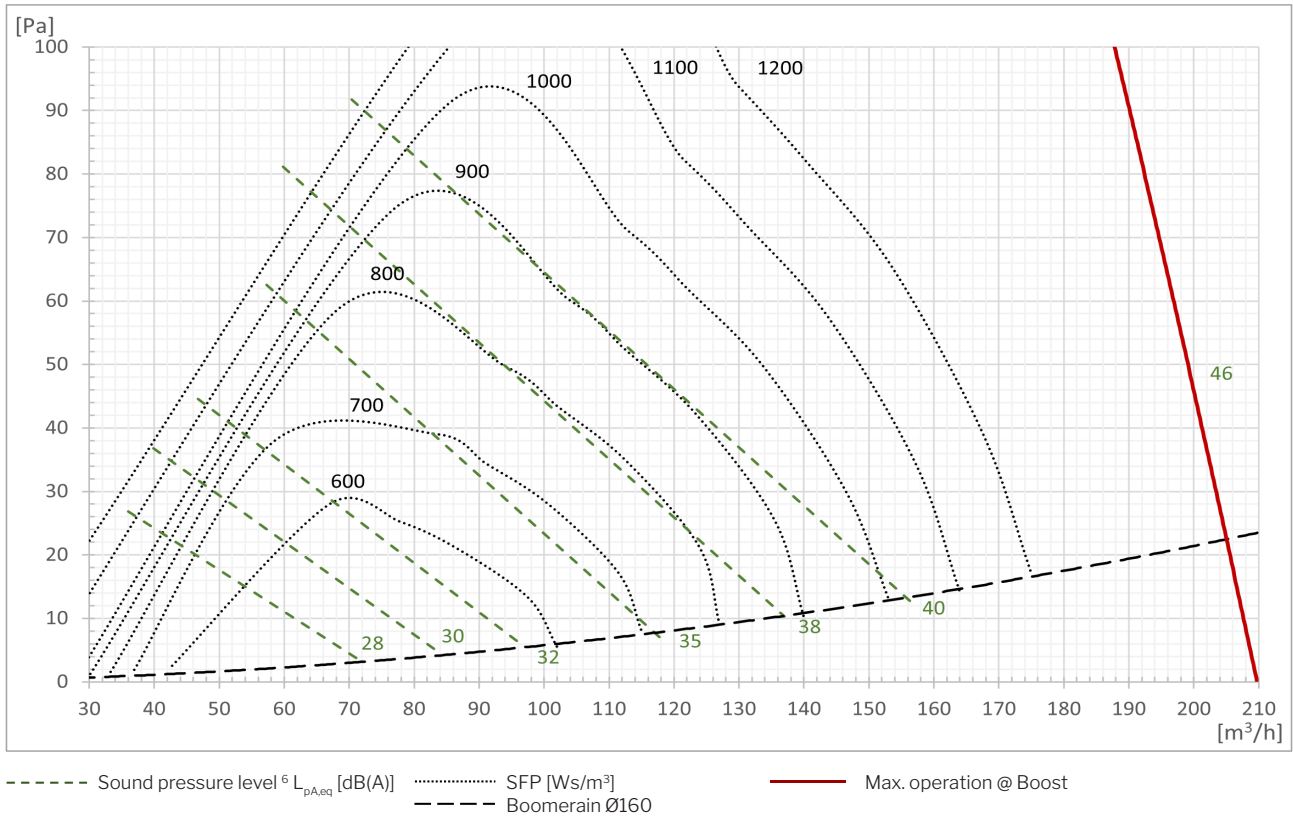

⁶ The sound pressure level L_{pA,eq} is measured at a height of 1,2 m at a horizontal distance of 1 m from the air handling unit.

SFP with ePM₁ 80% / ePM₁₀ 50% filters

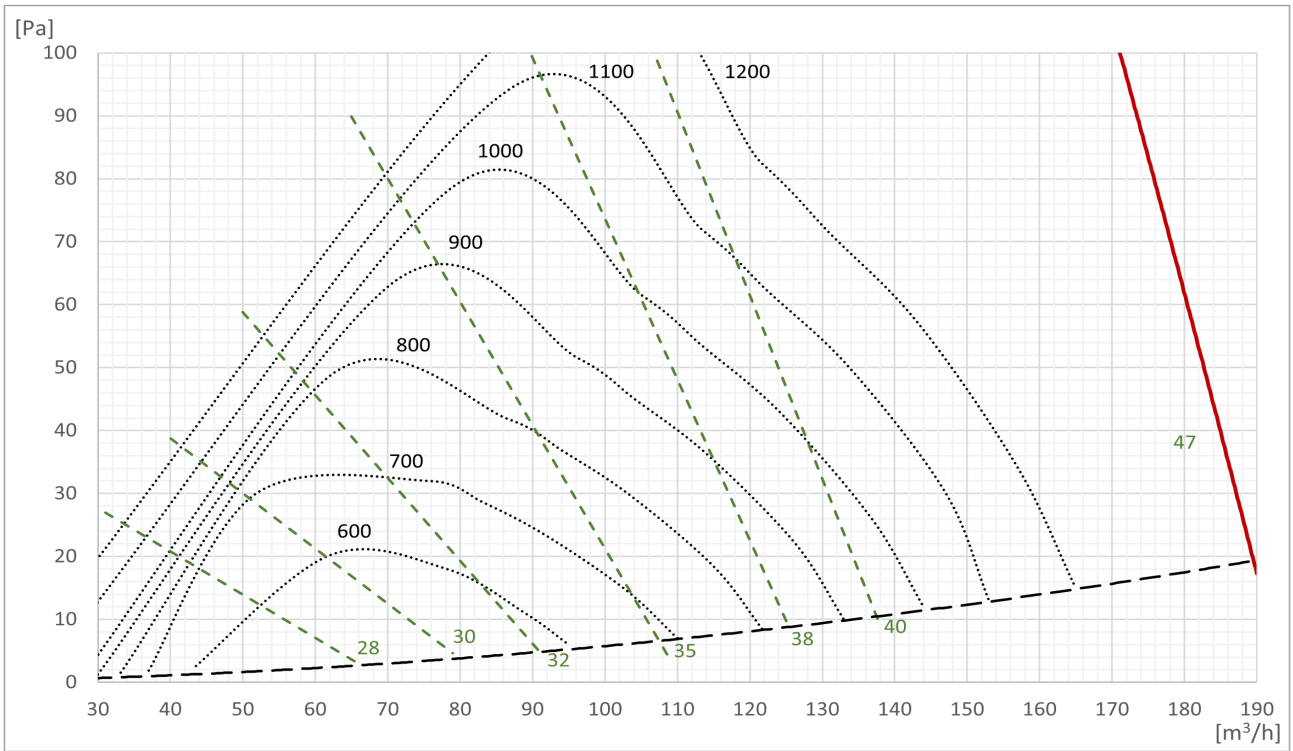

- - - - - Sound pressure level $^6 L_{pA,eq}$ [dB(A)] SFP [Ws/m³] ——— Max. operation @ Boost
 - - - - - Boomerain Ø160

Sound pressure level ⁷L_{pA,eq} acc. to Airmaster reference situation

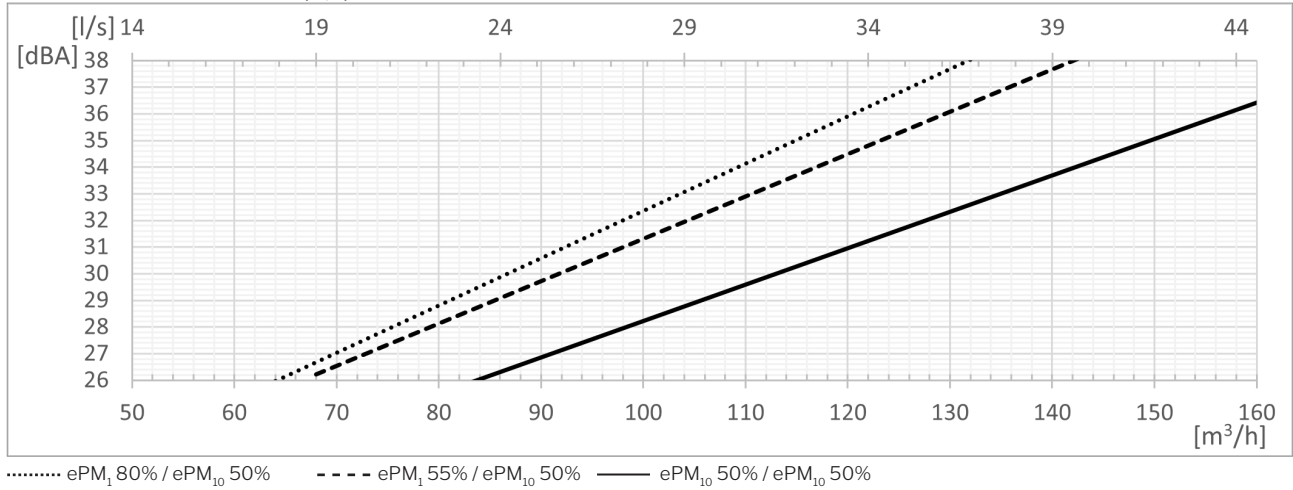

Temperature efficiency acc. to EN 308

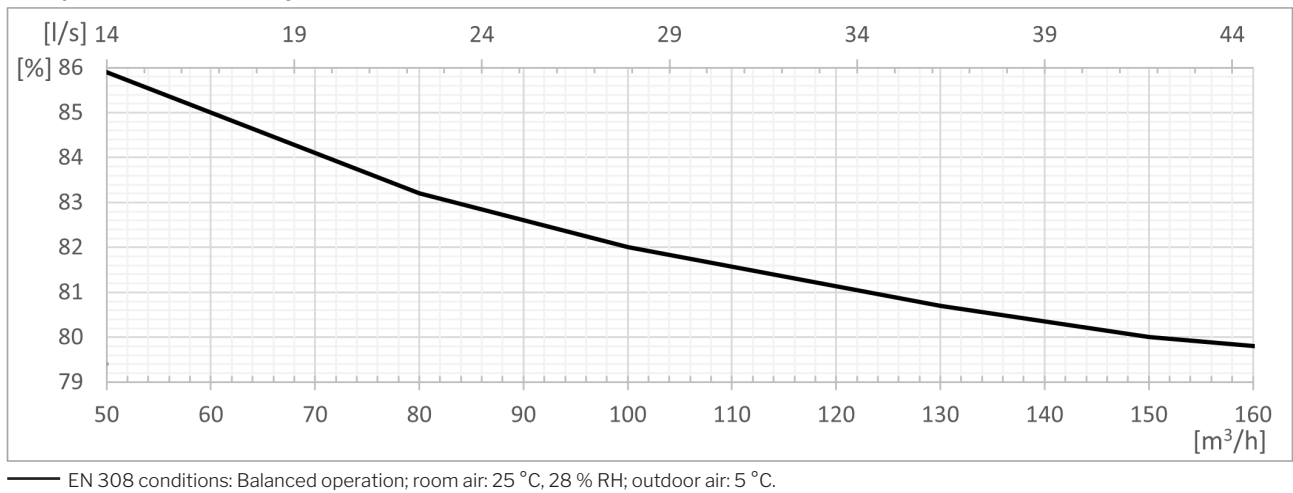

Power consumption

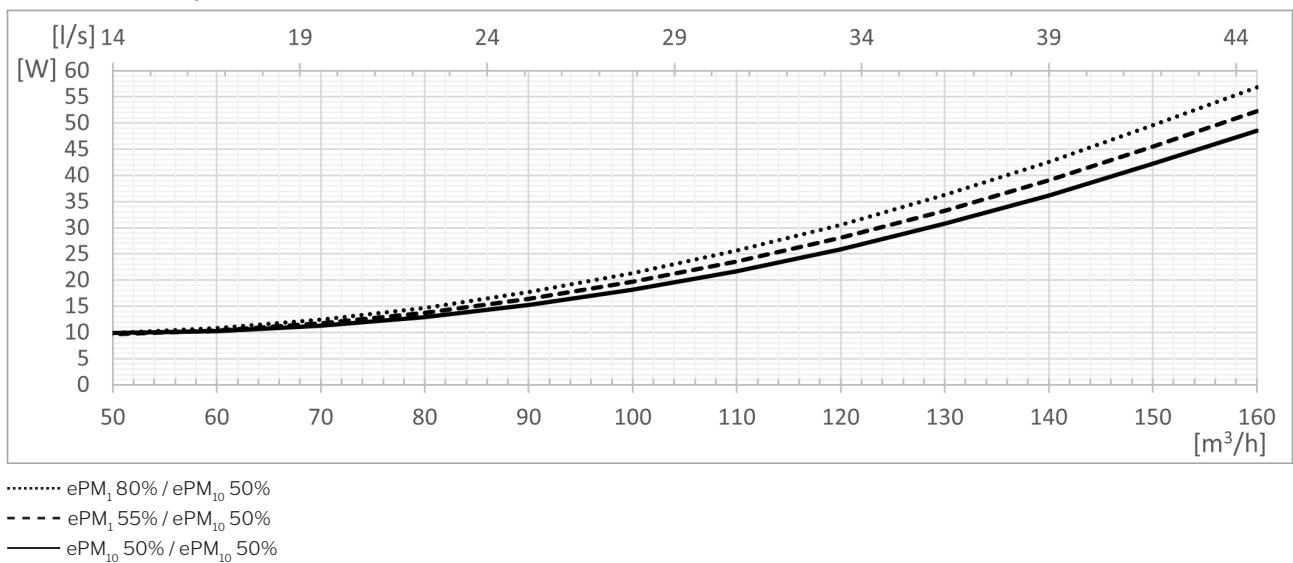

⁷ The sound pressure level L_{pA,eq} is measured at a height of 1.2 m at a horizontal distance of 1 m from the air handling unit.

SFP⁸

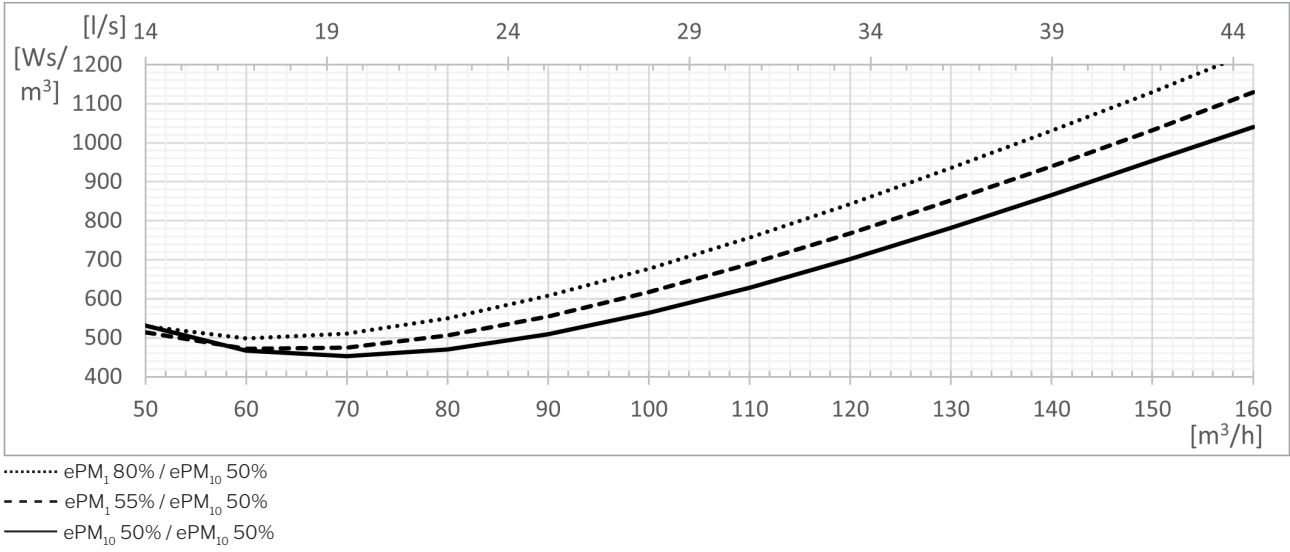

⁸ The calculation of SFP includes the power consumption for operating fans but not for controls, display panel, etc.

Throw⁹ (0,2 m/s)

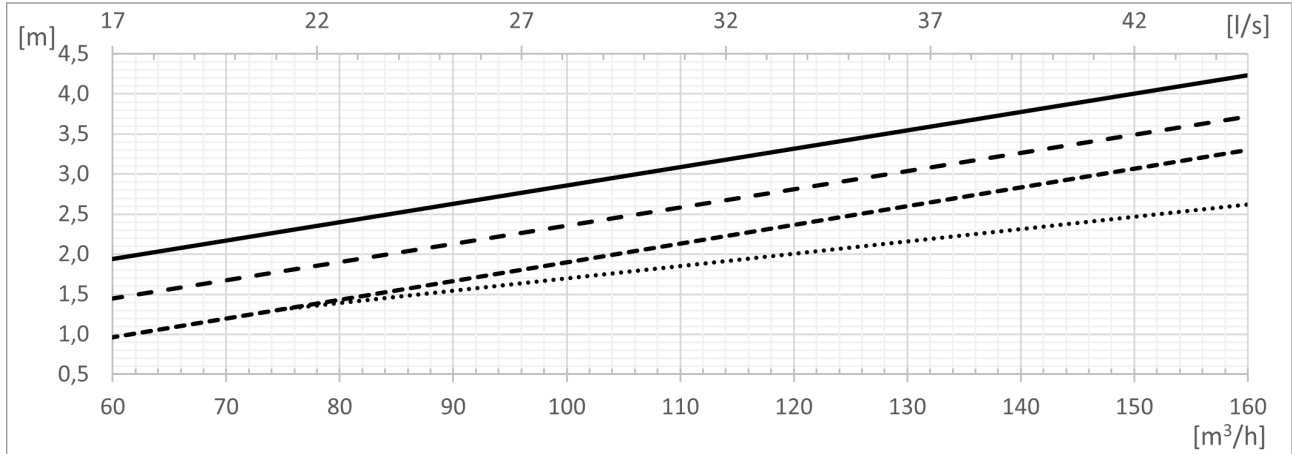

- Small inlet diffuser opening, 30° blade angle.
- - - Small inlet diffuser opening, 45° blade angle.
- Large inlet diffuser opening, 60° blade angle.
- - - - Large inlet diffuser opening, 45° blade angle.

Small and large inlet diffuser opening

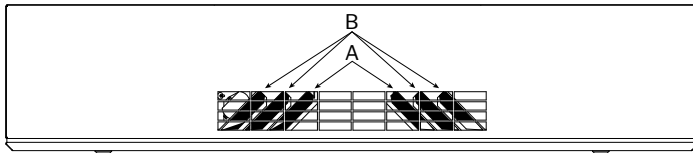

Small inlet diffuser opening:
A is closed, B is open at x° .

Large inlet diffuser opening:
A and B are open at x° .

Default delivery state:
Small inlet diffuser opening, 45° blade angle.

Throw and dispersion, top view.

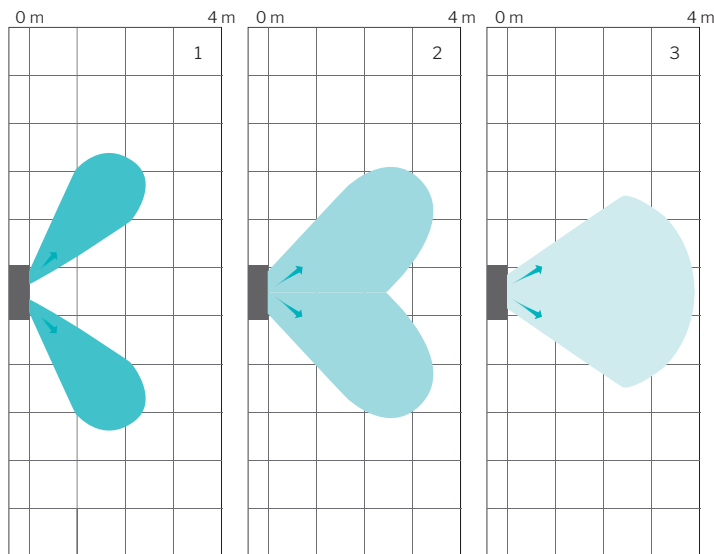

The air handling unit disperses inlet air depending on the blade angle settings.

The illustrations show the dispersion pattern and throw for the various blade angle settings at an air flow of 146 m³/h:

1. Large inlet diffuser opening, 60° blade angle.
2. Small inlet diffuser opening, 45° blade angle.
3. Small inlet diffuser opening, 30° blade angle.

Changing the air flow also affects the throw length.

Throw, side view.

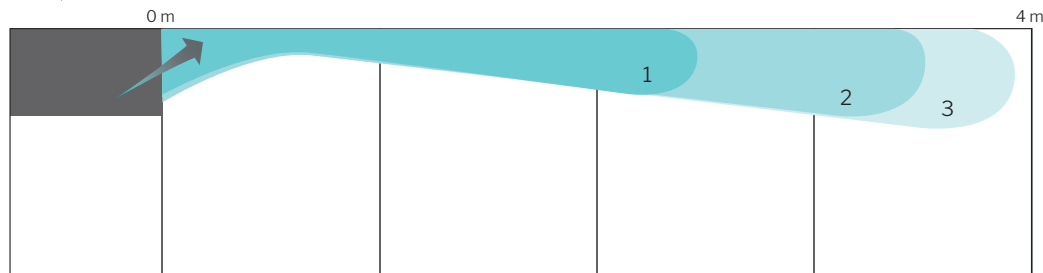

⁹ The throw is measured with a 2 °C subcooled inlet air supply.

Version overview

AM 150 with CC 150 (Comfort Cooling Module (CC))

Exhaust/supply position
» Back (**H**orizontal)

Inlet/extract position
» Bottom (**B**)
» Ducted Inlet (**DI**)
» Ducted Extract (**DE**)

Mounting
» Wall/ceiling bracket

HH BB - CC

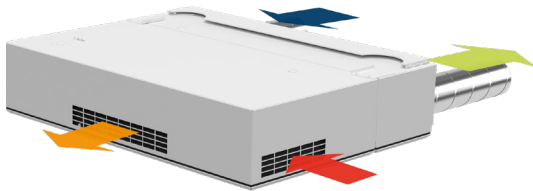

HH BDE - CC

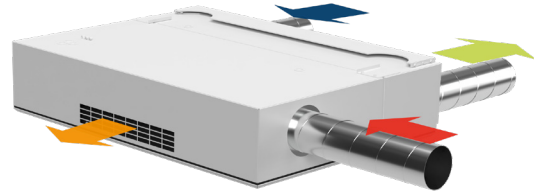

HH DIB - CC¹⁰



HH DIDE - CC¹⁰

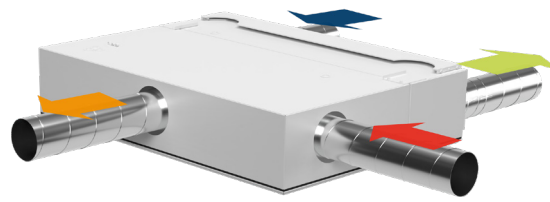

Standards and options

Counterflow heat exchanger (PET)	x
Enthalpy counterflow heat exchanger (polymer membrane)	o
Combination counterflow heat exchanger (polymer membrane)	o
Motor-driven bypass	x
Motor-driven supply air damper	x
Motor-driven extract air damper	x
Electric heating surface/VPH ¹¹	•
Condensate pump	•
Service power switch	•
Electronic humidity sensor (built-in)	•
PIR/motion sensor (wall mounted)	•
PIR/motion sensor (integrated)	•
CO ₂ sensor (wall mounted)	•
CO ₂ sensor (integrated)	•
TVOC (integrated)	•
CO ₂ -/TVOC sensor (integrated)	•
Hygostat (wall mounted)	o
Energy meter	•
Supply air filter ePM ₁₀ 50%	•

Supply air filter ePM ₁ 55%	•
Supply air filter ePM ₁ 80%	o
Extract air filter ePM ₁₀ 50%	x
LED (operating mode indicator)	x
Comfort cooling module	•
Wall/ceiling bracket	•
Ceiling frame	•
Operating button	•
Control panel, Viva	•
Control panel, Orbit	•
Airmaster Airlinq® Online	•
Airlinq® Online API	•
Airlinq® BMS	•
LON® module	o
KNX® module	o
MODBUS® RTU RS485 module	•
BACnet™ MS/TP module	•
BACnet™ /IP module	•

X : Standard • : Optional o : Special item (not stock item)

¹⁰ Special item

¹¹ Virtual PreHeat

Schematic sketch

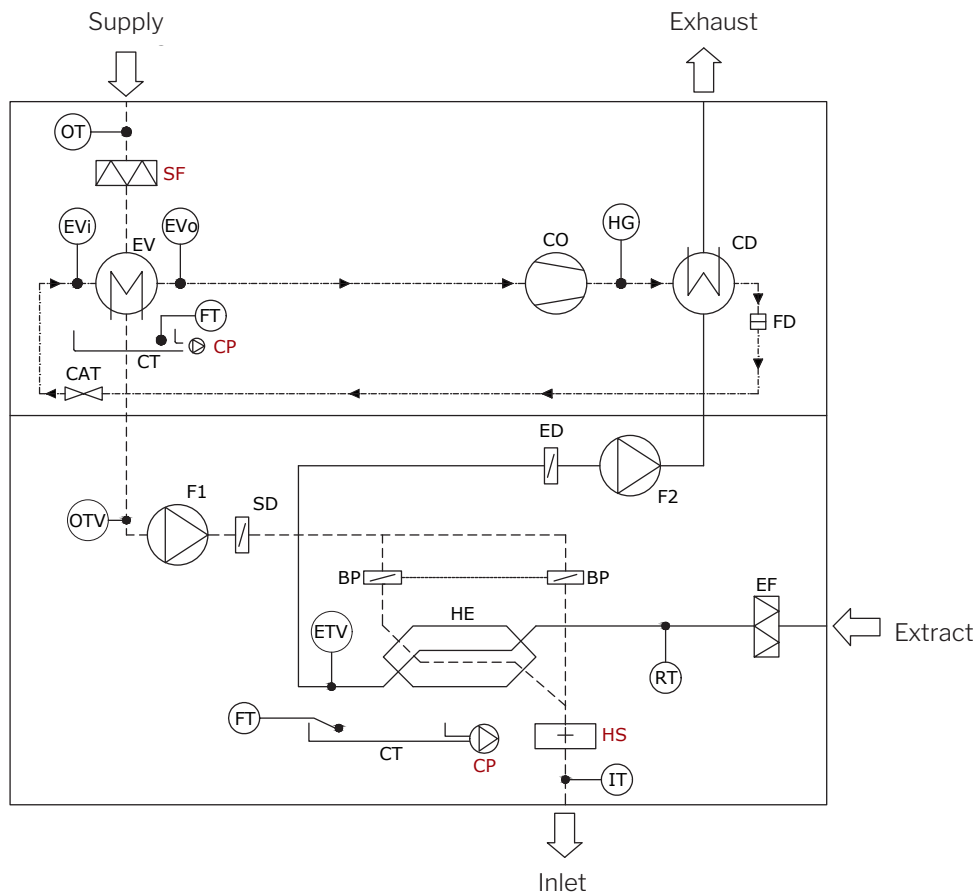

Component designation

BP	Bypass damper (motor-driven)	EV	Evaporator	HS	Electric heating surface (option)
CAT	Capillary Tube	EVi	Temperature sensor, Evaporator in	IT	Temperature sensor, Inlet-air
CD	Condenser	EVo	Temperature sensor, Evaporator out	OT	Temperature sensor, Supply air
CO	Compressor, inverter Controlled	FD	Filter Dryer	OTV	Temperature sensor, Supply air ventilation
CP	Condensate pump (option)	FT	Float	RT	Temperature sensor, Room
CT	Condensate tray	F1	Supply air fan	SD	Supply air damper (motor-driven)
ED	Exhaust air damper (motor-driven)	F2	Extract air fan	SF	Supply air filter (option)
EF	Extract air filter	HE	Counterflow heat exchanger		
ETV	Temperature sensor, Exhaust, Ventilation	HG	Temperature sensor, Hot Gas		